

# Functional Overview of Hydraulic Vehicle Engine Mount Classification

S.S. Hosseini<sup>1</sup>, J. Marzbanrad<sup>2</sup>

<sup>1</sup> PhD Student at School of Automotive Engineering, Iran University of Science and Technology, <sup>2</sup> Faculty at School of Automotive Engineering, Iran University of Science and Technology,

marzban@iust.ac.ir

## Abstract

Car design incorporates many engineering sciences where today, have led to the use of advanced technologies in automobiles to provide more satisfaction and comfort for the passengers, increase the quality of vehicles, efficiency and more pleasure than previous cars. These issues can be categorized into two groups in general. In the first group, the effects and performance of components involved in vehicle vibrations are considered, and in the second group, attention is paid to the importance of joints and junctions of these components. Heretofore, in order to minimize vehicle NVH (noise, vibration and harshness), an exuberance of efforts have been done to raise the passengers comfort. In the meantime, it should be noted that the engine mounts play a considerable and serious role in reducing vibration exchanged between the engine and chassis. In designing the engine mounts, the most important concern is to balance the two opposite criteria that come into the car as a result of different vibration inputs (road and motor). Generally, vehicle engine mounts are used by three types of targets (motor bearing weight, motor vibration absorption, motor overloading, acceleration or braking). With the development of the automotive industry, the tendency towards the use of more efficient engine mount categories, has been prepared.

This article describes a concise functional overview of the engine mount in automobiles; it illustrates operating frequency range, relationship of the P and boundary diagram of engine mounts with other car collections, torque roll axis, positioning public types of the car's engine mounts; and it also compares their operations. Afterwards, the structure and the basic functional of hydraulic engine mount are described as the most common engine mount categories. Finally, advantages and disadvantages of various types engine mounts with capability of use in the vehicle (including elastomeric, hydraulic (with inertia track or/and decoupler or/and bell plate (plunger), semi-active (switchable) and active hydraulic engine mount) are compared with each other.

**Keywords:** engine mounts, modeling, vehicle, functional classification

## 1. Introduction

The location of the engine mount in the vehicle is a junction between the engine and gearbox to the chassis, and its most momentous task is to separate the vibration from the engine to the body in order to increase the passenger's comfort and reduce noise and vibration. If this is not done well, the resulting forces cause quick fatigue in the vehicle components and discomfort for the passengers. [1] The approach to new design is to reduce vehicle weight and increase engine power. Therefore, in optimizing the engine

mounts, it is needful to ameliorate the function of hardness, depreciation, and the best engine mount location. [2] In other words, the most functions and properties of engine mount design for optimum of operating is:

1. The capacity of positioning and installing the engine mount in the engine compartment;
2. The capacity of reducing noise transmitted to the passenger's cabin;
3. The increase in vehicle maneuverability under load applied;
4. Bearing engine weight and isolating its misalignment of the vehicle body;

5. Avoiding weariness in engine and chassis in the junction;
6. Reducing range of vibration on chassis through engine and vice a vise;
7. Reducing tension concentration in engine and chassis in the junction;
8. Reducing the effect of vibration resulting from friction between the road and the vehicle;
9. A relative high displacement between body and engine;
10. Reducing noise level in the car;
11. Preventing harsh movement in the vehicle while accelerating including braking and changing gear.

**2. Application in the vehicle**

It is obvious that one of the most basic functional applications in different kinds of vehicles, including cars, is motive power which depends on its structure and body. This connection is made by a variety of engine mount categories among which the most functional applications is hydraulic engine mount in vehicles today. [3]

The below Figures represent some examples of numbers and layout of positioning the engines mount in several vehicles as well as its general model.

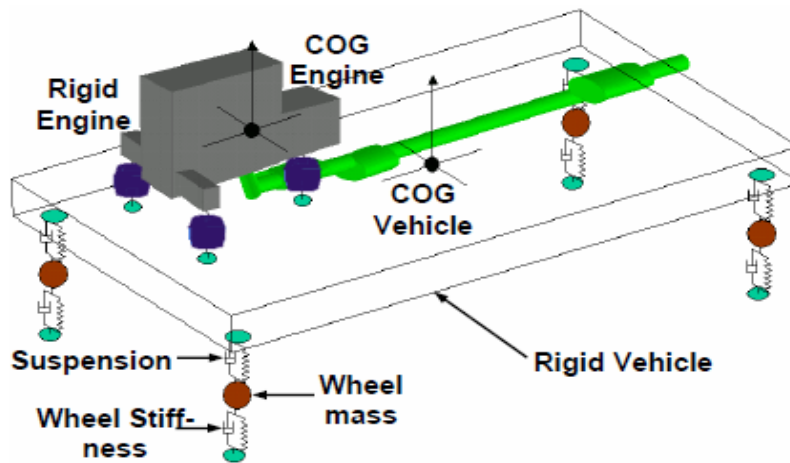
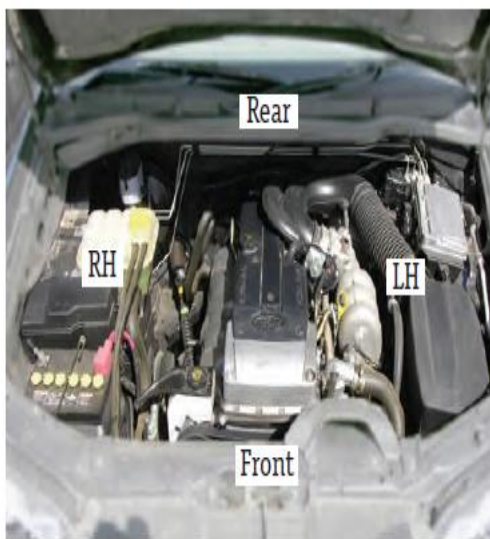

Fig1. Schematic overview of the engine mount position in the overall vehicle model

**A) Rear wheel drive**



**B) Front wheel drive**

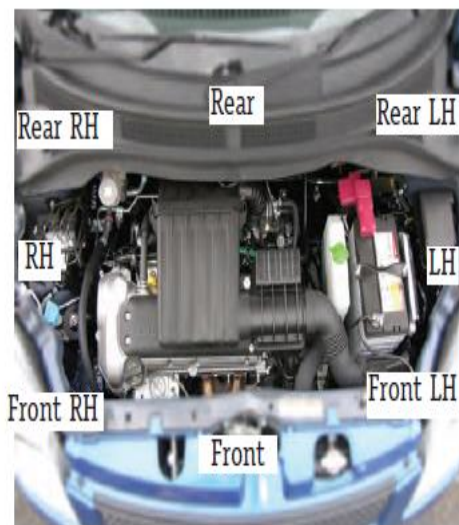

Fig2. Comparative overview of the engine mount location in the vehicle with front and rear wheels' drive

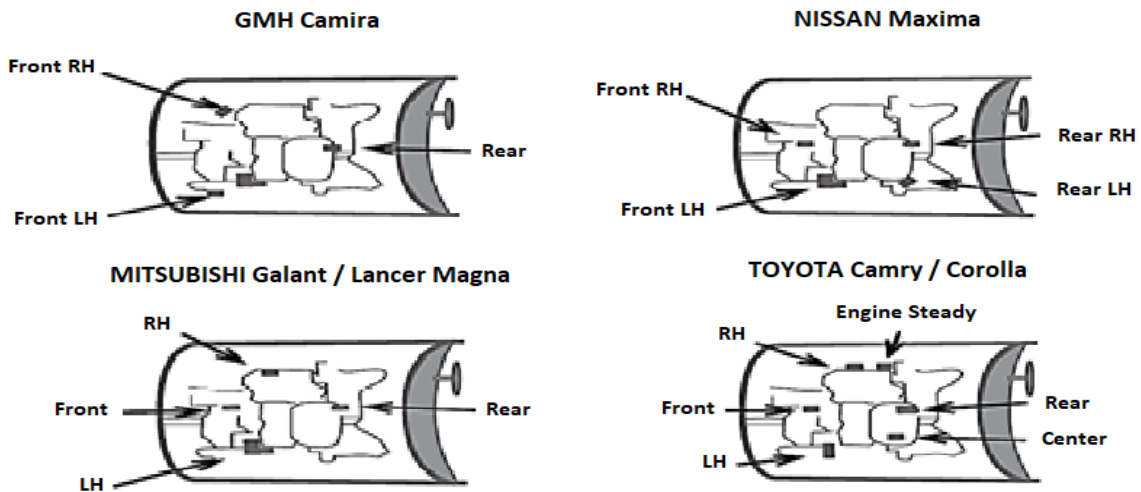

Fig3.. Bench marking of positioning, number and layout of engine mount in several vehicles



Fig4. Some types of engine mount used in the vehicles

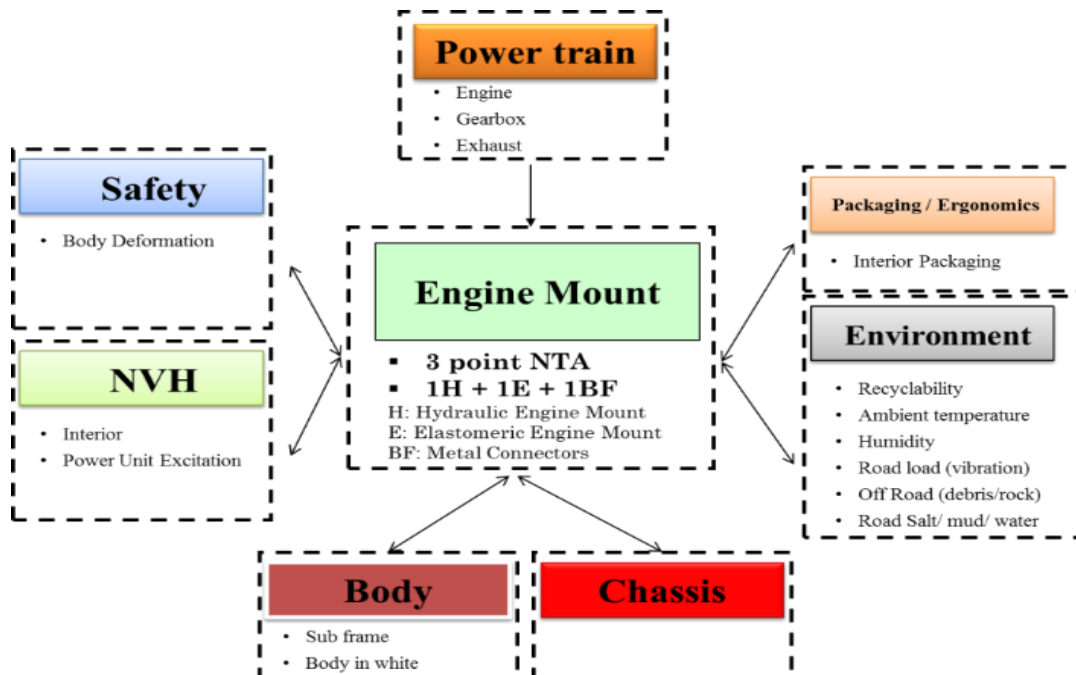

Fig5. Boundary diagram of the engine mount relation with other vehicle collections (general explanation of the collections)

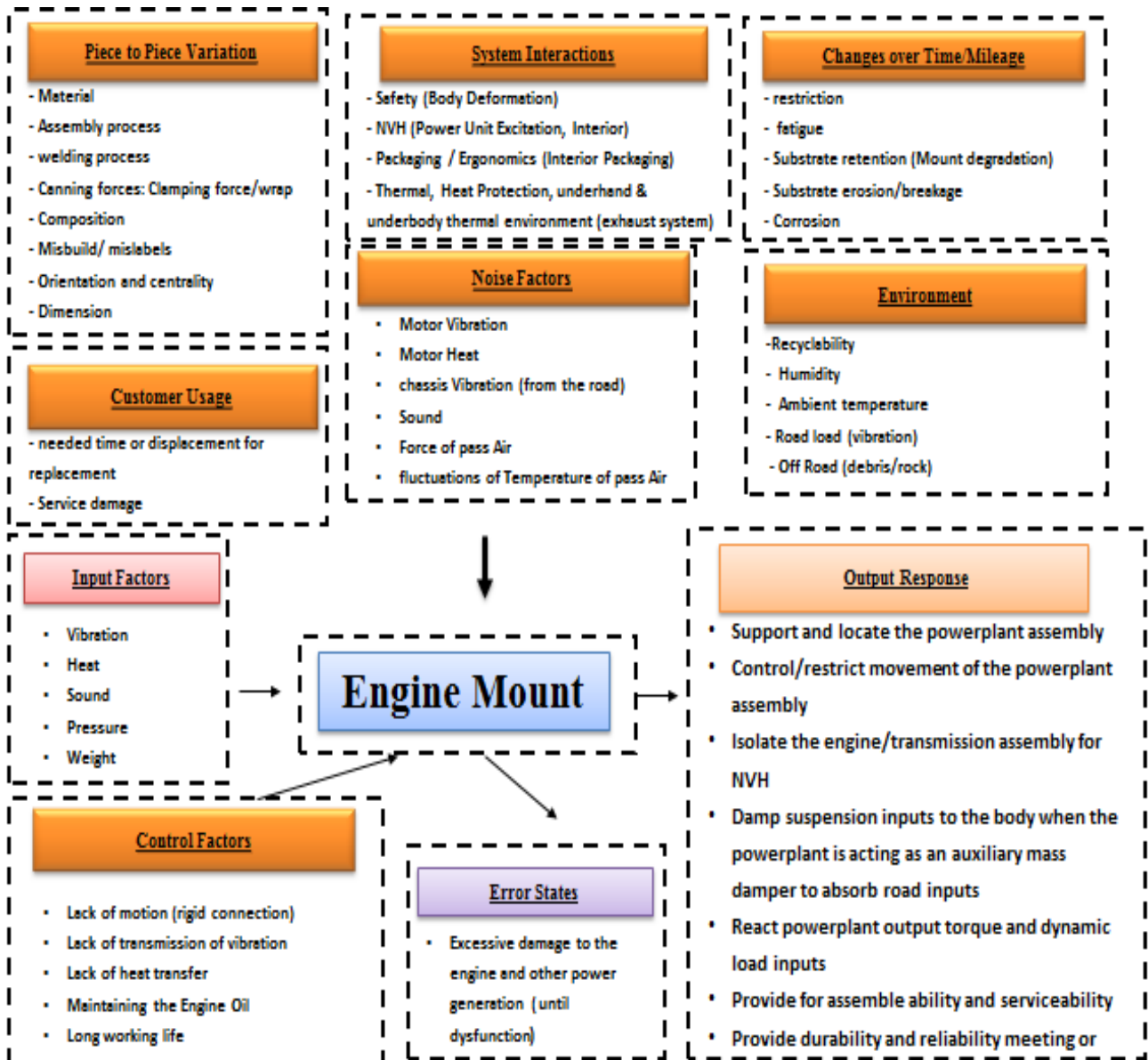

Fig6.P diagram of the engine mount (In it, the inputs, outputs, disturbances, control cases, and error states of this system are expressed)

Above, some types of engine mount used in the vehicles are presented.

Figure 5 illustrates engine mount boundary graph. The graph shows the relationship between engine mount with other systems of the car; For example, engine mount is installed on the body. Therefore, every change in each of them affects the other; so, an interaction between engine mount system and body is necessary. Process modelling and system identification using input-output data have always been the focus of many research efforts. [4] In accordance with the same process, in Figure 6, P diagram of engine mount is expressed in terms of

inputs, outputs, disturbances, control cases, and error states.

### 3. The most common type of engine mounts positioning system in the vehicle and comparing its functional applications

Similar to Figures 1 ~ 3, the most common types of engines mount positioning system in the vehicles for positioning engines mount are as follow:

- 1- Conventional method;
- 2- NTA - 3 point method;
- 3- NTA - 4 point method.

### 3.1 Standard 3 point

All three mounts provide weight support. One mount is located at the right-hand side (RHM) on the NTA, and the other two are located on the left-hand side at front and rear positions (LHFM, LHRM) of the engine. The LHFM and LHRM also support torque forces and are positioned at an inclined angle to match the elastic center to the NTA.

Torque roll axis (TRA) is taken into consideration in choosing three-point engine mount since the least vibration will be made if the engine and gearbox can be connecting to chassis through the two points passing this axis. The mentioned axis is an imaginary axis, connecting engine gravity center and gearbox. The axis is presented in the below schematic Figure.

Most effects of the engine match cross-connection on torque roll axis are its slow revolving and low frequency. When the location of engines mount is determined with regard to positioning limitations, and the distance from the aforesaid axis is studied, now it is the time to examine engine rigid modes and

gearbox and to place them in further distance from automotive modes. It is noteworthy that determining the exact number of engines mount and their categories depend on getting accurate information about other vehicle parts like engine, chassis and body.

### 3.2 NTA - 3 point

Two mounts aligned along the NTA on either side of the engine (LHM, RHM) carry the weight of the engine. A torque strut supports the output torque in the direction of expansion because of instability effects in compression. The bounce and pitch modes are uncoupled. Another advantage is that the PMS is relatively easy to tune for road input as well as for idle conditions. A disadvantage is that the layout is space demanding. A more compact PMS is built by placing the two mounts beneath the engine (low 3 point PMS), alternatively moving one mount away from the NTA (balanced 3 point PMS). [5]

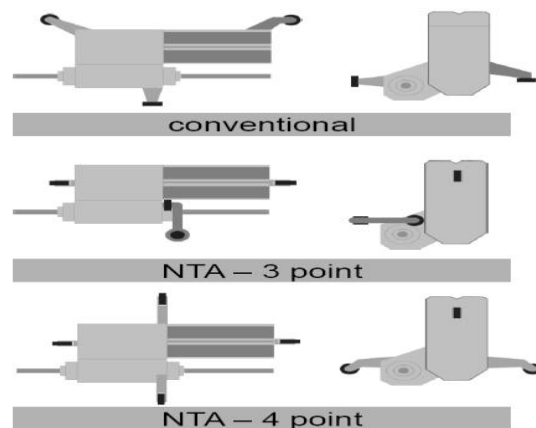

Fig7. The methods of engine mount positioning in the internal common types

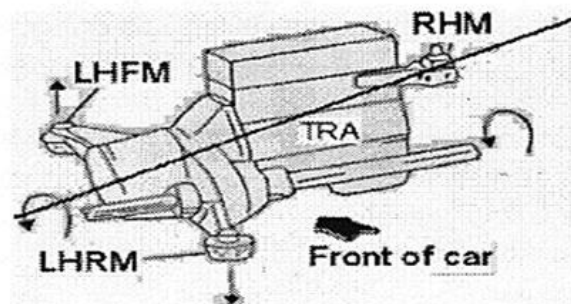

Fig8. Standard 3 point PMS

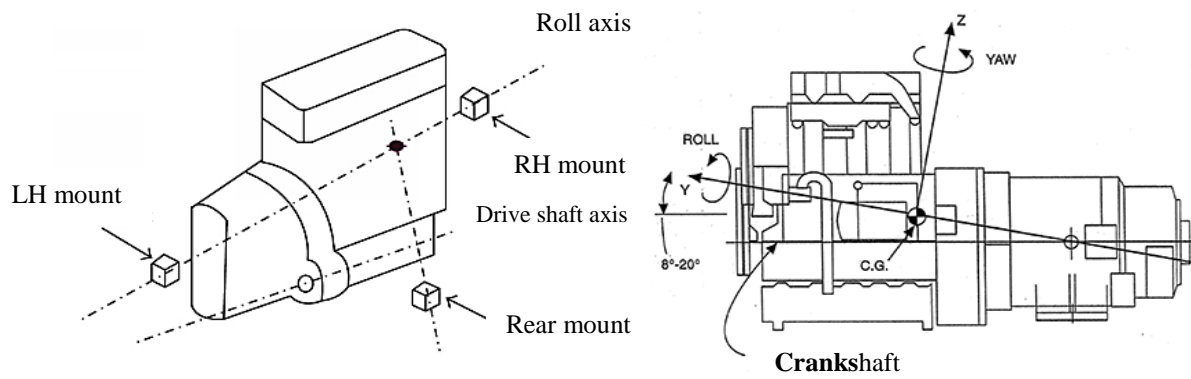

Fig9. Schematic situation of torque roll axis

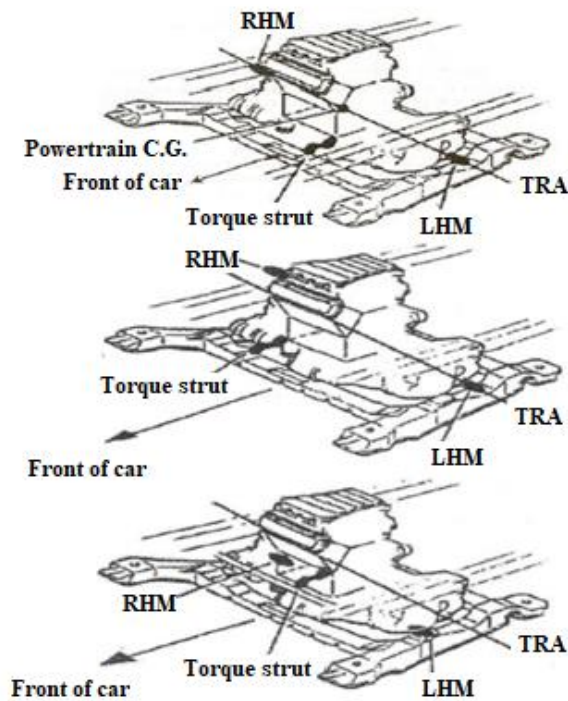

Fig10. From top: 3 point NTA PMS, a balanced 3 point NTA PMS, a low 3 point NTA PMS

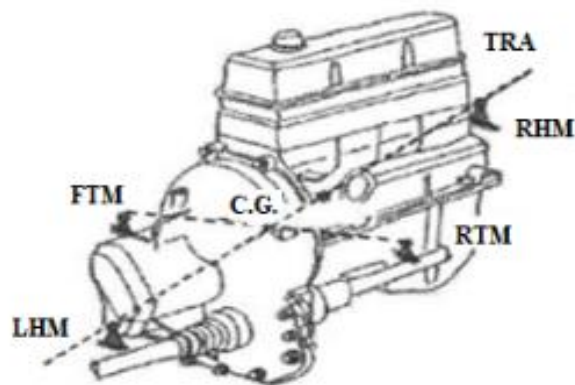

Fig11. 4 point NTA PMS

**Table 1.** Comparing the methods of engine mounts positioning

	<b>Conventional</b>	<b>3 point</b>	<b>4 point</b>
<i>Idle NVH</i>	more weakening	improvement	no positive or negative changes
<i>Cruising NVH</i>	more weakening	improvement	no positive or negative changes
<i>Idle: body bending excitation</i>	more weakening	improvement	more weakening
<i>Powertrain bending excitation</i>	Improvement	more weakening	more weakening
<i>Maximum static mount forces</i>	no positive or negative changes	more weakening	no positive or negative changes
<i>Tuning Potential</i>	more weakening	improvement	improvement
<i>Robustness to stiffness and</i>	more weakening	improvement	more weakening
<i>Package</i>	Improvement	no positive	more weakening
<i>cost</i>	Improvement	no positive	more weakening

### 3.3 NTA - 4 point

This strategy uses two side mounts for weight support, while engine torque is supported by two mounts at the fore and aft positions of the engine. According to [6], this setup can be somewhat problematic since pre-stresses can occur in the fore/aft mounts due to creep in the weight supporting mounts.

Generally, Conventional method aims to choose the connecting points in a way in which they are 120 degrees apart and In NTA 4-point method, the engine is assembled in 4 points with the angle of 90 degrees in each point; the same way in NTA 3-point method, which is often applied for most vehicles, two connecting points are selected on the right and left sides of transversal direction of the vehicle; in addition, a point in the middle of these two points are selected on cradle part to limit the engine movement in longitudinal direction. In order to control longitudinal movement, an anti-roll bar is placed on engine mount on top right.

The advantages and disadvantages of different positioning were compared to each other in table 1.

## 4. Mounts

There are two measures to characterize a mount in a PMS, the static Force vs. Displacement (F-D) relation and the Dynamic Stiffness Loss Angle (DSL). The F-D relation of a mount is designed by using the requirements of natural frequencies of the PMS, usually in the range of 6 – 18 Hz [6], see tables 2 and 3.

The DSLA of a mount under low frequency and large amplitude is developed based on reduction of displacement of the powertrain C.G. and the forces transmitted to the car body. Minimization of cabin noise and the vibration of steering wheel and seat rail determine the suitable DSLA of a mount under high frequency and small amplitude excitations.

**Table 2.** Important vehicle frequency ranges (Typical excitation and natural frequencies of vehicle subsystems) [6]

Excitation or NVH performance	Frequency (Hz)
<i>Body movement (body rigid modes)</i>	1-3
<i>Drive train (shuffle)</i>	7-8
<i>PMS rigid mode</i>	6-18
<i>Body bending and torsional mode</i>	20-35
<i>Wheel hop</i>	11-14
<i>Steering column bending mode</i>	28-35
<i>Tyre /wheel - excitation</i>	1-35

**Table 3.** Important vehicle frequency ranges (Excitation or NVH performance vs. frequency) [6]

Excitation or NVH performance	Frequency (Hz)
<i>Idle shake, vibration and boom</i>	5-50
<i>Road induced shake</i>	10-15
<i>Take off judder</i>	10-30
<i>Switch on / off vibration</i>	5-20
<i>Tip in / back out</i>	3-10
<i>Drive noise and vibration</i>	20-500
<i>Steering column vibration</i>	25-40
<i>Power train boom and harshness</i>	50-500

### 5. Operational frequency range of the engine mounts

The automotive engine-chassis-body system may undergo undesirable vibration due to disturbances from the road and the engine. [7]The most significant reason for using engine mount is to reduce undesirable vibrations imposed on the passengers is caused by motor misalignment and unevenness of the road, which leads to improving the vehicle vibrational operation. The most important reason for popularity of self-regulating engine mount is changeability of the system vibrational features in different ranges and frequencies of stimulation imposed on vehicle engine. From the point of view of designing engine mount and loading conditions and from the point of view of noise and vibrations, the undesirable vibrations happening in automobile are classified into two general types. [8]

First type, the conditions, through which low frequency vibration along with vast vibrational range are used in the engine; and road conditions, rapid acceleration (rapid accelerations which cause extra torque happening in the engine and its influence on engine mount as a result), sudden braking, changing gear are among the factors which create this type of

vibration. The stimulation frequency of this type is below 30 Hz and its amplitude is over 0.3 mm.

Second type, the vibrations which are exerted on the engine when the automobile is switched on, vibrations of high frequency and pretty low amplitude. The amount of centrifugal force of the engine is the most important element in creating this type. This type includes frequencies of 25 to 200 Hz and stimulation amplitude less than 0.3mm.

Consequently, in order to remove the damages caused by the two above mentioned types of vibrations, automobile needs two types of engine mount of different function; one with high hardness and damping for the first type of vibration, which is known as shock absorber and the other one with low damping for the second type of vibration, which is known as vibrational isolator. Thus, the features of an ideal engine mount depend on the conditions of stimulation amplitude and frequency. An elastomeric (normal) engine mount of linear characteristics cannot satisfy two above mentioned aims. It can be deduced that an ideal engine mount is a system of non-linear hardness and damping, which depends on the conditions of stimulation amplitude and frequency. Therefore, dynamic hardness of an ideal engine mount must somehow follow the diagram of Figure 12. [9]

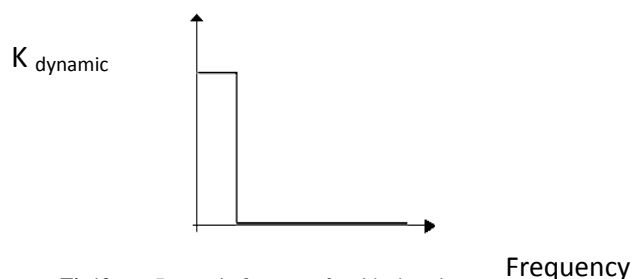
**Fig12.** Dynamic features of an ideal engine m

As you can see, in low frequencies, high damping is required to avoid the vehicle bounce (a kind of sudden vertical movement along the floor to ceiling engine is not damaged. Hydraulic engine mount provides such conditions for idealizing engine mount.

## 6. An overview on input displacements of engine and road in the vehicle's engine mounts

In order to examine the performance of the engine mounts, first, different types of the engine mounts are taken into consideration. The operation, dynamic models, and other issues related to engine mounts are discussed.

Reducing vehicles weight is a method used for reducing fuel consumption in vehicles. Body mass reduction leads to increasing the ratio of engine weight to the weight of its body, and to increasing frequency and vibration level as a result. Therefore, many complex hydraulic engine mounts have been produced to remove this problem. However, since it is necessary to minimize the vehicle's production cost, the engineers have to design complex hydraulic engine mounts in a limited timeframe.

### 6.1 Road simulation (movement)

The major stimulation for engine mounts is vibrational stimulation of low frequency and high amplitude transferred by road and suspending system to the vehicle's body. In order to describe and ideal engine mount, this system is simplified to one-degree freedom model illustrated in Figure (13). Where,  $m$  is engine mass,  $k$  is engine mount hardness, and  $c$  is the characteristics of engine mount attenuation (decoupler). [10] Regarding the movement of the vehicle's body as  $y(t)$ , the movement equation of the system will be as follow:

$$k(y - x) + c(\dot{y} - \dot{x}) = m\ddot{x} \quad (1)$$

Assuming Sinusoidal input and output in constant mode, the equation will change to equation in frequency area. Since engine mount features should minimize the relative displacement between the engine and the body, frequency equations are written so that they show the relative displacement transfer. Thus we will have the next equation:

$$\frac{(X - Y)}{Y} = \left| \frac{\omega_{dr}^2 m}{-\omega_{dr}^2 m + \omega_{dr} c j + k} \right| \quad (2)$$

axis of the vehicle) and to maintain Random Sustainability. Low damping is also required in high frequencies for ideal vibrational separation so that the

where  $\omega_{dr}$  is stimulation frequency. Equation (1) is simplified by using attenuation (decoupler) coefficient without aspect  $\zeta = c / (2\sqrt{mk})$ ; and it is illustrated in Figure (14) versus the ratio of  $r = \omega_{dr} / \omega_n$  frequency which includes  $\omega_n = \sqrt{k/m}$ .

Figure 14 shows relative displacement transferability in frequency limit. This Figure explains the ideal frequency working area for the minimum ratio of engine displacement to the body. Stimulation frequency of the path unevenness must be less than the system natural frequency. Increase in engine mount hardness causes a bigger natural frequency as well as high range vibration in displacement isolated area. In addition, increase in attenuation (decoupler) will reduce resonance, and develop relative displacement. Sinusoidal procedure is one of the most efficient methods applied in many papers to simulate the road model. Deshpandeh et al. introduces the following model for simulating the road model:

$$Z_r = 0.05 \sin(1.5\pi t) \sin(0.15\pi t) + 0.05 \cos(0.6\pi t) \sin(0.3\pi t) \quad (3)$$

The graphs of the outputs are demonstrated in Figures 15 and 16 in terms of situation and velocity.

Road equation can also be presented as follow:

$$z_r = A \sin\left(\frac{2\pi v}{L} t\right) \quad (4)$$

As it can be seen, the equations are related to the vehicle speed. Besides,  $A$  equals 0.1 m and  $L$  equals 2m. The simulation diagrams accomplished for simulating road unevenness are presented in Figures 17 and 20 for the vehicle three different speeds.

For more precise and reality-based simulation of the road, statistical procedures can also be used to explain the road condition. In reality, road unevenness is also random; and statistical simulation can be efficient in better explaining road condition based on reality. Research on road statistical simulation has been conducted by Robson et al [11], and Rotenberg. Rotenberg's suggested equation is as follow: [12]

$$S(\omega) = \frac{\sigma_1^2 \alpha_1 v}{\pi \omega^2 + \alpha_1^2 v^2} + \frac{\sigma_2^2 \alpha_2 v (\omega^2 + \alpha_2^2 v^2 + \beta^2 v^2)}{\pi (\omega^2 + \alpha_2^2 v^2 - \beta^2 v^2) + 4 \alpha_2^2 \beta^2 v^4} \quad (5)$$

where  $\omega$  is angular frequency,  $V$  is vehicle velocity,  $\alpha_1, \alpha_2, \beta, \sigma_1^2, \sigma_2^2$  coefficient related to road type. All these values are presented in table 4.

The chronological background of road unevenness can be obtained by the following equation:

$$\ddot{w} + (a_1 + a_3)\dot{w} + (a_0 + a_1 a_3)w + a_0 a_1 w = d_1 (\xi + b_3 \dot{\xi} + b_0 \ddot{\xi}) \quad (6)$$

In this equation, the parameters are:

$$\begin{aligned} a_0 &= -(\alpha_2^2 + \beta^2)v^2, & a_1 &= \alpha_1 v, \\ a_2 &= 2(\alpha_2^2 - \beta^2)v^2, & a_3 &= (a_2 + 2a_0)^{0.5} \\ b_0 &= -\frac{[\sigma_1^2 \alpha_1 (\alpha_2^2 + \beta^2) + \sigma_2^2 \alpha_1 \alpha_2 (\alpha_2^2 + \beta^2)]^{0.5} v^{2.5}}{b_4^{0.5}} \\ b_2 &= \frac{[2\sigma_1^2 \alpha_1 (\alpha_2^2 - \beta^2)^2 + \sigma_2^2 \alpha_2 (\alpha_1^2 + \alpha_2^2 + \beta^2)] v^3}{b_4} \\ b_3 &= (b_2 + 2b_0)^{0.5}, & b_4 &= (\sigma_1^2 \alpha_1 + \sigma_2^2 \alpha_2) v \\ d_1 &= \left(\frac{b_4}{\pi}\right)^{0.5} \end{aligned}$$

Simulation graphs of the road condition and velocity which are presented in Figures 19 and 20 based on statistical equations.

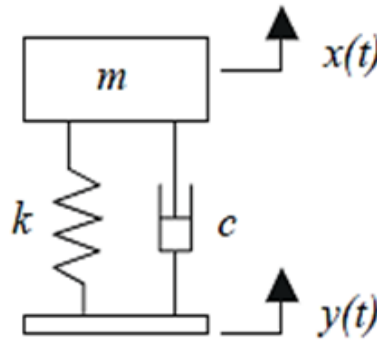

Fig13. Stimulation with low frequency; vibrational system of one-degree freedom

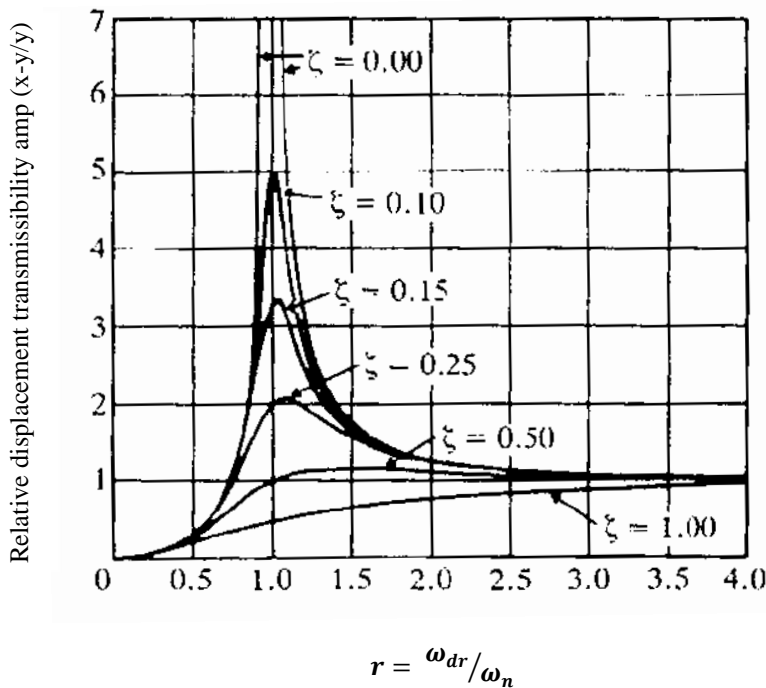

Fig14. Stimulation with low frequency; relative displacement transferability in frequency area

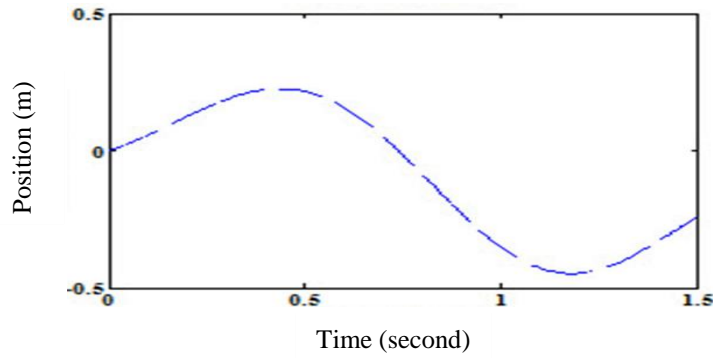

Fig15. Diagram of condition of road unevenness, sinusoidal equations

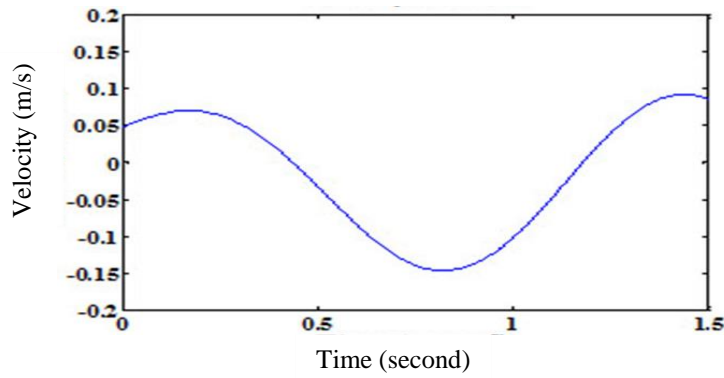

Fig16. Diagram of velocity of road unevenness, sinusoidal equations

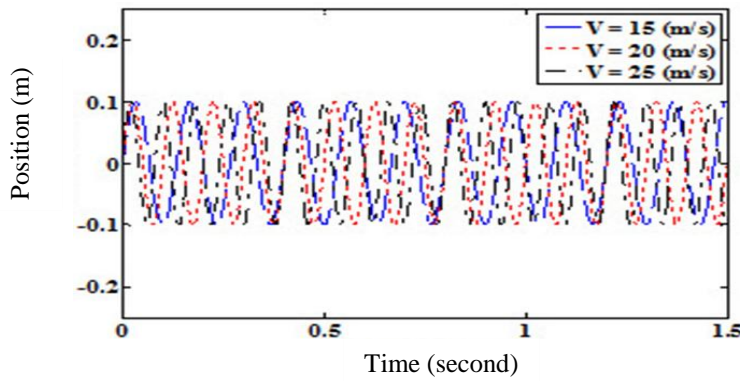

Fig17. Diagram of condition of road unevenness based on sinusoidal equations dependent on vehicle speed.

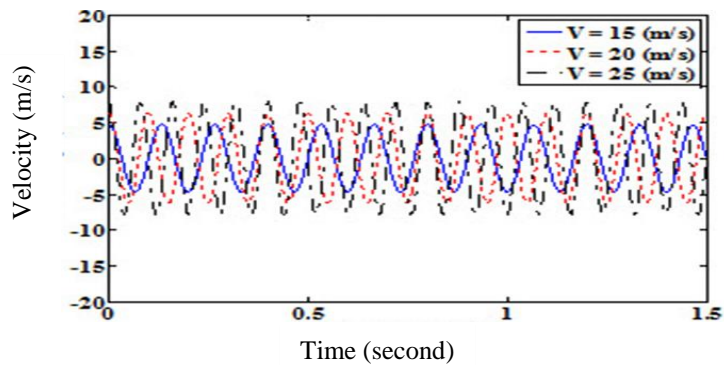

Fig18. Diagram of velocity of road unevenness based on sinusoidal equations dependent on vehicle speed

Table 4. Values applied in road statistical model [13]

$\alpha_1 (m^{-1})$		0.5
$\sigma_z^2 (m^2)$		$4.5 \times 10^{-3}$
$\sigma_1^2 (m^2)$		$2.55 \times 10^{-4}$
$\beta (m^{-1})$		2.0
$\alpha_2 (m^{-1})$		0.2

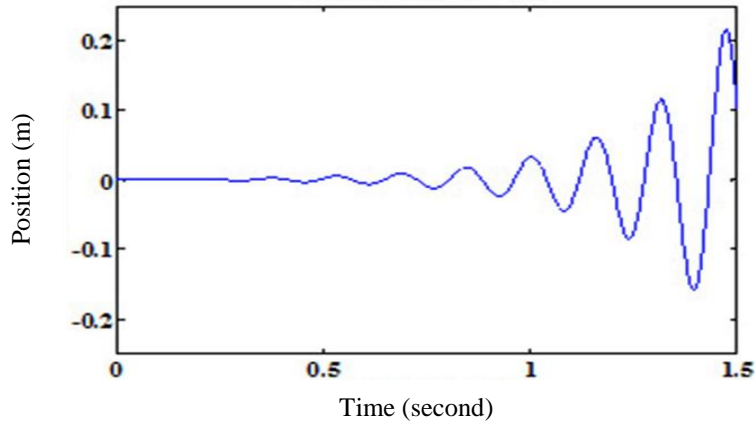

Fig19. Diagram of condition of road unevenness according to statistical model

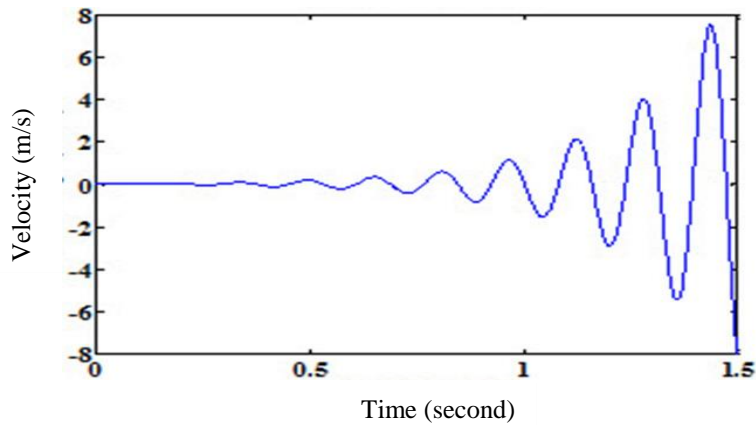

Fig20. Diagram of velocity of road unevenness according to statistical model

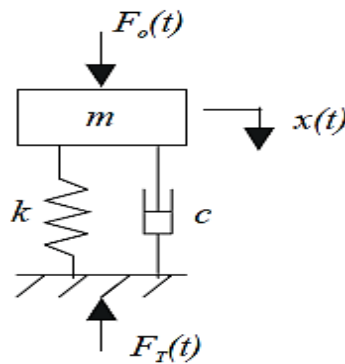

Fig21. Simulation with high frequency; power stimulation of the system of one-degree freedom

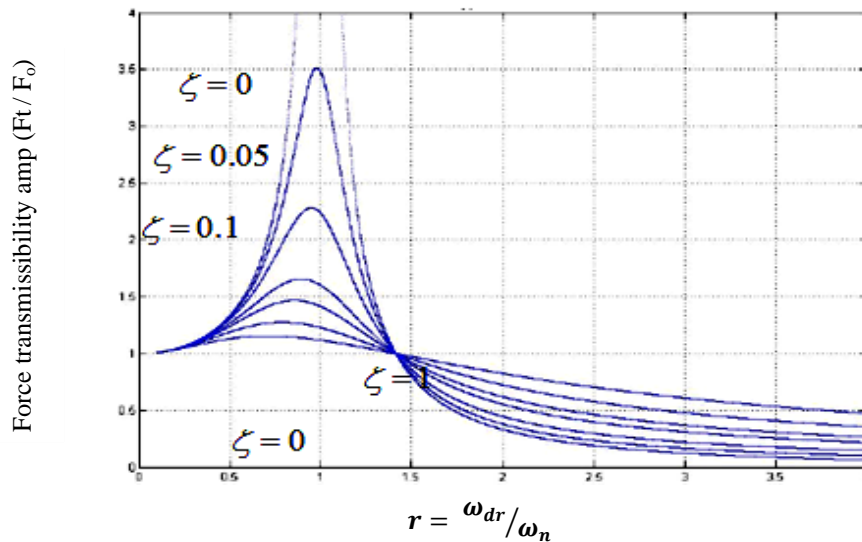

Fig22. Simulation with high frequency; diagram of transferred power in relation to frequency area

**6.2 Being simulated by motor counterbalance (lake of balance)**

High and low frequency vibration result from the vehicle engine counterbalance, tis stimulation can be expressed as the power reached to one-degree freedom system shown in Figure (21). Power reached to engine is represented as  $F^o$ . The incoming power from engine counterbalance and  $F_t$  show the incoming power through vehicle body to engine mount. The motor equation achieved for the system is as follow:

$$F_T = c\dot{x} + kx \tag{8}$$

$$F_o = m\ddot{x} + c\dot{x} + kx \tag{9}$$

The ratio of transferred power to input (incoming) power,  $\frac{F_T}{F_o}$  expresses power transferability. Using this equation and fixed analysis in frequency area, the next equation is obtained: [8]

$$\frac{F_T}{F_o} = \left| \frac{c\omega_{dr}j + k}{-\omega_{dr}^2 m + c\omega_{dr}j + k} \right| \tag{10}$$

As an example for stimulating engine mount pile, dimensionless attenuation (decoupler) and the ratio of frequency for showing the frequency reply are explained in Figure (22). In this condition, motor vibration must operate in isolated area, higher that engine natural frequency and engine mount system. Engine mount of low hardness reduces natural frequency of the vehicle body. Small attenuation (decoupler) feature also reduces transferability. The above mentioned analysis determines ideal aspects of

engine mount. In spite of low frequency and high vibrational range, the direction of decreasing relative transitional displacement, an ideal engine mount shows high hardness and attenuation (decoupler). However, in high frequency and low amplitude, the ideal engine mount must have low hardness and attenuation (decoupler). These contradictory properties indicate that in ideal engine mount, the qualities related to hardness and attenuation (decoupler) depends on stimulation range. This attachment to stimulation range is considered in designing hydraulic engine mount.

**7. Engine mount categories**

In relation to the general classification of different technologies types in the engine mounts, the following categories can be introduced:

1. Elastomeric Engine Mount
2. Hydraulic engine mount
  - 2.1. Hydraulic engine mount with Inertia track
  - 2.2. Hydraulic engine mount with Inertia track and decoupler
  - 2.3. Hydraulic engine mount with Inertia track and decoupler and Bell plate(Plunger)
3. Switchable hydraulic engine mount
4. Semi-active hydraulic engine mount
5. Active hydraulic engine mount

Then, in brief, we give a general explanation of engine mount categories regarding their functional advantages and disadvantages.



Fig23. Elastomeric Engine Mount



Fig24. Hydraulic engine mount with Inertia track



Fig25. Hydraulic engine mount with Inertia track and Decoupler

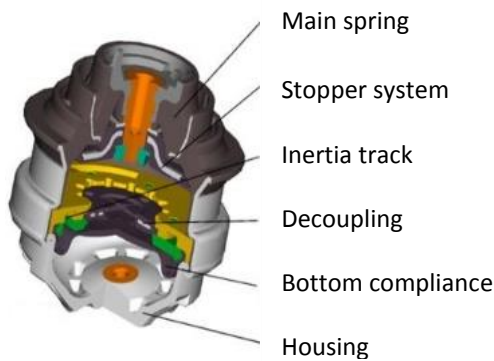

Fig26. Hydraulic engine mount with Inertia track and Decoupler and Bell plate(Plunger)

### 7.1 Elastomeric engine mount

In order to isolate the vehicle structure from engine's vibrations, elastomeric engine mount have been used since 1930s. Today, it still uses in most vehicles as one of the engines mount. (Shown in Figure 23)

Below, we briefly refer to advantages and disadvantages of elastomeric engine mount.

- The advantages of elastomeric engine mount
  1. Isolation of engine vibrations in all directions
  2. Los costs (costs for design, production, and maintenance)
  3. Long life
- Disadvantages of elastomeric engine mount
  1. Increase in dynamic hardness by increasing frequency
  2. Inability in simultaneous isolation of stimulation (movements) of high frequency and stimulation (movements) of low frequency

### 7.2 Passive hydraulic engine mount

It was invented and applied in the world car industry since 1962. Increasing current vehicle development trends for small, light, front wheel drive vehicles with low idle speeds have been forced automotive industries to use hydraulic engine mount s for further improvement in Vibration, Noise, and Vibration and Harshness (NVH) performance of their vehicles. [14]

Its different categories are as follow:

1. Hydraulic engine mount with inertia track
2. Hydraulic engine mount with inertia track and decoupler
3. Hydraulic engine mount with inertia track and decoupler and Bell plate(Plunger)

All three types are the same in terms of their function and performance. (Figures 24, 25, 26)



Fig27. Switchable hydraulic engine mount

In the following, we refer simply to advantages and disadvantages of the passive hydraulic engines mount.

- Advantages of the passive engines mount
  1. Illustrating variable mechanical properties with frequency changes of stimulation (high hardness and damping in low frequencies, and low hardness and damping in high frequencies); and consequently, the ability of isolating a wide area of stimulating frequencies
- Disadvantages of the passive hydraulic engine mount
  1. High costs
  2. Less durability (due to mechanism high sensitivity)

### 7.3 Switchable hydraulic engine mount

In order to set the system dynamic reaction, one or more than one mechanical parameter (damping and hardness) can be controlled by this type of engine mount. [15] The control circuit overall scheme of this type of engine mount is in the form of open circuit. (Displayed in Figure 27)

Below, advantages and disadvantages of semi-active hydraulic engine mount are explained.

- Advantages of semi-active hydraulic engine mount
  1. Adjustability of the engine mount performance and effectiveness domain based on the type of stimulations and intended conditions
- Disadvantages of semi-active hydraulic engine mount
  1. High costs
  2. Less durability

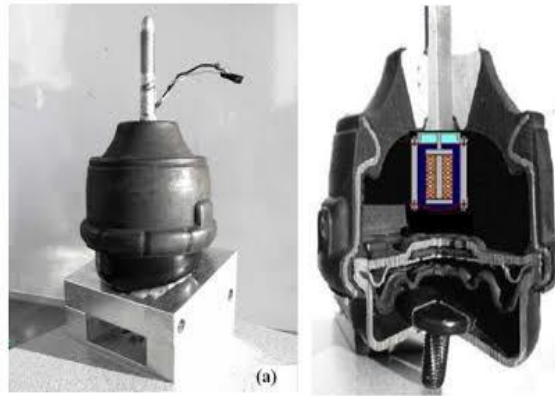

**Fig28.** Semi-active hydraulic engine mount

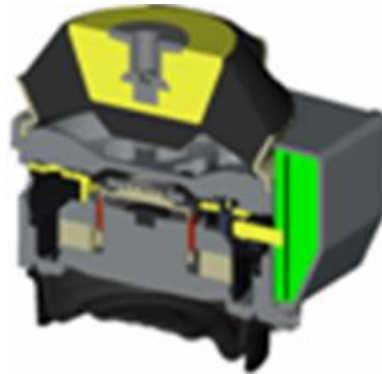

**Fig29.** Active hydraulic engine mount

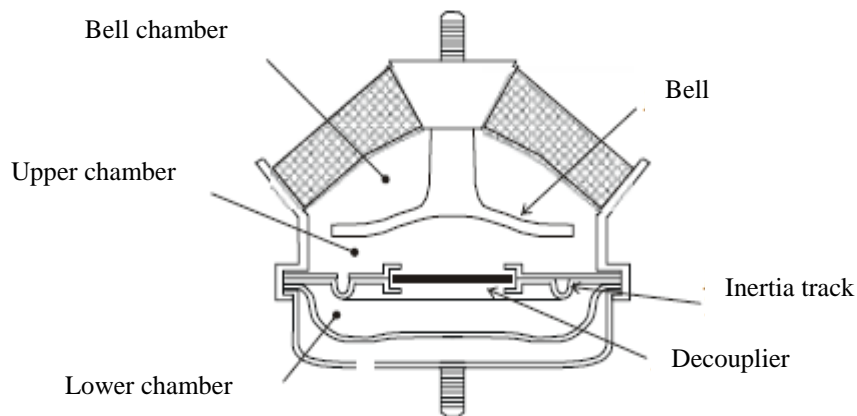

**Fig30.** The general parts of a hydraulic engine mount [21]

#### 7.4 Semi-active hydraulic engine mount

Passive hydraulic engine mount cannot isolate some of input stimulations well (for example, engine stimulations (movements) in IDLE situation). In semi-active hydraulic container, some engine mount mechanical parameters are controlled by a CCTV (closed-circuit television), limited control system. Therefore, the ability to isolate it is highly powerful,

and it covers some of disadvantages of passive hydraulic engine mount. At present, this type of engine mount is used in luxurious, advanced automobiles [16], (Figure 28).

Below, we refer to advantages and disadvantages of half-active hydraulic engine mount in simple words.

- Advantages of half-active hydraulic engine mount

1. Better isolating wider area of stimulating frequencies (specially, stimulation of low frequency)
2. Controllability of desired values of the system mechanical parameters
  - Disadvantages of half-active hydraulic engine mount
    1. Very high costs
    2. Less durability (due to the mechanism high sensitivity)
    3. Lack of good efficiency in stimulation of high frequencies
5. High vulnerability (due to highly sensitive mechanism and control circuit components)
6. Efficiency drop in stimulation of low frequencies

## 8. The structure of hydraulic engine mount

The hydraulic engine mount includes two general parts; the basic elastomeric part and the hydraulic part, which leads to ideal dynamic behavior during the system operation. Figure 30 shows the components of a sample system.

### 7.5 Active hydraulic engine mount

By new advancements in vehicle manufacturing; vehicle quality evaluation and assurance has become a more critical issue. [17] In order to control vibrations actively, this type of engines mount includes an active source of energy, which constantly creates a dynamic neutralizing force by an operator to neutralize the effects of stimulating forces and to reduce transitional force. Active container (preservative) is made of a passive container (elastomeric or hydraulic), a power generator, a vibrational neutralizer, and an electrical controller. [18]

The latest research achievements on these engines mount refer to a variety of power generators. Some researchers have introduced electromagnetic forces as dynamic neutralizing force. [19] Some others have suggested piezoelectric; and accordingly, this type of engines mount has divided into special categories. This category of engines mount is under study, and has not fully been commercialized yet. However, it is predicted that the active container will be used widely in automotive industry in future [20], (sample of that displayed in Figure 29).

Below, we refer to advantages and disadvantages of active hydraulic engines mount.

- Advantages of active hydraulic engines mount
  1. Highly ideal isolation wider area of stimulating frequencies (specially the stimulations of high frequencies), and extraordinary improvement of vehicles status in terms of noise level.
- Disadvantages of active hydraulic engines mount
  1. Very high costs
  2. Numerous parts and components
  3. Heavy weight
  4. Energy consumption

The hydraulic part includes two Fluid-filled chambers. The fluid can be a mixture of antifreeze with ethylene glycol. [22] Incompressibility, no chemical reaction with plastic, metal and adhesives components, high boiling point and cavitation pressure are important factors in choosing the fluid. The bottom of the lower chamber is made of a flexible rubber sheet, which is bent under pressure and transfer the performance of an opening and closing source to the lower chamber. The upper chamber is closed from below by separating steel plate which is composed of two crossing channels. The plate is fixed to the base of engine mount. The two chambers are connected to one another by two channels called inertia track and decoupler. Inertia track is sometimes called damping channel. Decoupler is a rigid plastic pot which is hanging in its place; and it can swing freely (depending on exerting conditions) in its motion span. If an engine mount has only inertia track, it imposes very high damping on the system in low frequencies (high stimulation amplitude); but just like elastomeric engines mount, it encounters a problem in high frequencies (low stimulation amplitude) and causes a lot of hardness for the system, which is undesirable in high frequencies. Decoupler is applied to solve the problem. [23] Depending on the amplitude, decoupler stimulates the behavior of the engine mount. [24] This small disc, which acts like a floating piston, let the fluid pass through the chambers in low stimulation amplitude. Thus, in such conditions, hydraulic engine mount acts like elastomeric engine mount. Since fluid resistance does not interfere in system's behavior, and it is the only major operational part of the main elastomeric engine mount, this behavior causes engine mount dynamic behavior with low damping coefficient that leads to ideal features of vibrational separation stimulated by high frequencies (low amplitude). High stimulation range (amplitude) leads to satirizing decoupler performance, closes its channel, and directs the fluid toward the inertia track.

Channel's high resistance against the liquid flow increases other dynamic features of the system. In order to obtain the accurate behavior of hydraulic engine mount in all stimulation frequency spans, each of its components must be modeled in a correct way.

In high frequency and low amplitude stimulation, the fluid passes through decoupler; and due to decoupler little resistance against passing, the system turns into a normal engine mount. In stimulation with vast amplitude, decoupler sticks to the body, and the fluid passes through inertia track of higher resistance.

**9. Modeling of the hydraulic engine mount with inertia track and decoupler and bell plate (plunger)**

Figure 31 illustrates dynamic model of hydraulic engine mount with regard to inertia track and decoupler and piston. In this picture,  $x_r(t)$  and  $x_c(t)$  are according to displacement of the upper compliance and chassis, that leads to current rate of

$Q_u(t)$  in upper chamber,  $Q_L(t)$  in lower chamber,  $Q_i(t)$  in inertia track, and  $Q_d(t)$  in decoupler. Through upper and lower movements resulting from excitation frequency, piston rubber on the top acts as coil, damper, and transformer, and transfers this frequency to fluid energy with rates of current  $Q_s$ , pressure  $P_{u1}(t)$ ,  $P_{u2}(t)$ ,  $P_{L1}(t)$ , and  $P_{L2}(t)$ , in two places, as it is demonstrated in the mentioned Figure. Piston is fixed with piston rubber (the underneath main rubber which includes fluid). It also acts as moderate in damping as well as in transferring pressure from the chamber to chassis support (pile). The upper and lower surfaces are made up of a sandwich structure with decoupler and inertia track in between. As inertia track provides the large vibration range of low frequency with remarkable damping, the decoupler along with piston rubber on the top control the vibration of small vibrational range and low frequency. [25]

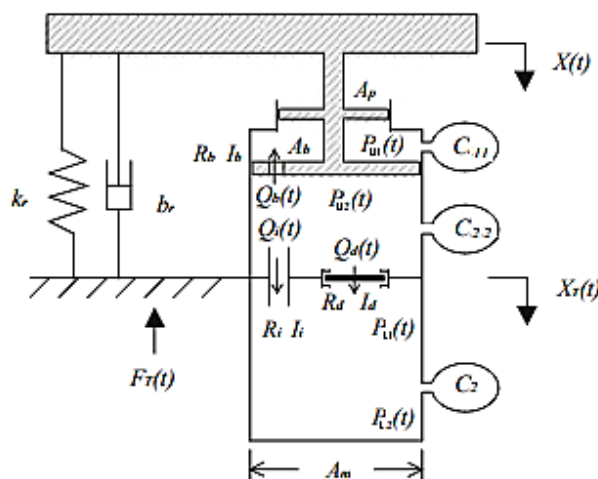

**Fig31.** Dynamic model of hydraulic engine mount with regard to inertia track, decoupler and piston

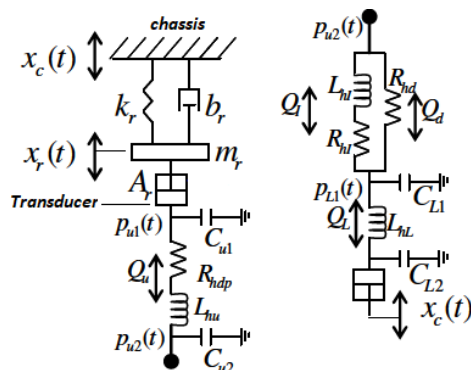

**Fig32.** Equivalent system and graphic limits of mechanical model of hydraulic engine mount with regard to inertia track, decoupler and piston

Figure 32 demonstrates equivalent system and graphic limits of mechanical hydraulic model with regard to inertia track, decoupler, and piston. Here,  $m_r$ ,  $b_r$ ,  $k_r$ ,  $A_r$ , are mass, damping coefficient, shearing stiffness, and primary area of main rubber respectively.  $C_{u1}$  and  $C_{u2}$  indicate hydraulic capacities each includes piston rubber and decoupler with liquid in the upper chamber. Similarly,  $C_{L1}$  and  $C_{L2}$  are hydraulic capacities which include the undermost rubber with fluid in the lower chamber.  $L_{hu}$ ,  $L_{hl}$ ,  $L_{hd}$ ,  $L_{hL}$  are fluid hydraulic inductance in the upper chamber, inertia track, decoupler, and the lower chamber.  $R_{hdP}$ ,  $R_{hd}$ ,  $R_{hl}$  illustrate piston hydraulic resistances, the decoupler hole, and inertia track.

For functional role of piston rubber as a transformer, we have the equation below: [26]

$$m_r \ddot{x}_r = -k_r (x_r - x_c) - b_r (\dot{x}_r - \dot{x}_c) - A_r p_{u1} + F(t) \quad (11)$$

where  $F(t)$  is excitation force coming from the engine. In order to study dynamic behavior of the hydraulic engine mount, chassis can be considered as a fixed frame. Therefore, its displacement ( $x_c$ ) equals 0. Furthermore, ignoring hydraulic resistances of the upper and lower chambers walls versus the fluid and applying Kirchhoff's voltage law for the upper chamber, inertia track, decoupler, and the lower chamber, the following equations is obtained: [27]

$$p_{u1} - p_{u2} = R_{hdP} Q_u + L_{hu} \dot{Q}_u \quad (12)$$

$$p_{u2} - p_{L1} = R_{hl} Q_I + L_{hl} \dot{Q}_I \quad (13)$$

$$p_{u2} - p_{L1} = R_{hd} Q_d + L_{hd} \dot{Q}_d \quad (14)$$

$$p_{L1} - p_{L2} = L_{hL} \dot{Q}_L \quad (15)$$

Similarly, it can be possible to ignore hydraulic capacity of inertia track and hydraulic inductance of the decoupler. Because the track is metal and much harder than rubber and liquid and since the fluid inertia of the decoupler is smaller than the liquid of the upper chamber, inertia and the lower chamber. Thus, applying Kirchhoff's voltage law for the upper chamber, inertia track, decoupler, and lower chamber the next equation is achieved: [28]

$$A_r \dot{x}_r = C_{u1} p_{u1} + Q_u \quad (16)$$

$$Q_u = C_{u2} p_{u2} + Q_1 + Q_d \quad (17)$$

$$Q_1 + Q_d = C_{L1} p_{L1} + Q_L \quad (18)$$

$$Q_L = C_{L2} p_{L2} + A_r \dot{x}_c \quad (19)$$

In equations (16) to (19), hydraulic capacity of  $C_{u1}$ ,  $C_{u2}$ ,  $C_{L1}$ ,  $C_{L2}$  can be computed as following:

$$C_{u1} = \frac{A_r l_r (1 - 3\nu^2 - 2\nu^2)}{(1 - \nu^2)E_r} + \frac{A_r l_r}{2B_f} \quad (20)$$

$$C_{u2} = \frac{V_u}{2B_f} + C_{hd} \quad (21)$$

$$C_{L1} = C_{L2} = \frac{\pi d_b^4}{32 t_b E_r} + \frac{\pi d_b^2 l_L}{8B_f} \quad (22)$$

Equations (20) to (22),  $l_r$  is the thickness of piston rubber as a standing cylinder,  $\nu$  is the ratio of Poisson module and  $E_r$  Young's rubber module.  $l_u$ ,  $l_L$  are the height of upper and lower chambers in balanced status (at equilibrium).  $d_b$ ,  $t_b$  are the diameter and thickness of undermost rubber?  $C_{hd}$ ,  $B_f$  are equivalent capacity of the decoupler and Bulk fluid module. Incompressible fluid is considered to compare it with rubber. Therefore, in these equations, the capacity can be calculated without the fluid capacity.

Likewise, in equations (16) to (18), hydraulic inductance of  $L_{hu}$ ,  $L_{hd}$ ,  $L_{hl}$ ,  $L_{hL}$  can be calculated by the following expressions:

$$L_{hu} = \frac{l_L \rho}{A_r} \quad (23)$$

$$L_{hl} = \frac{\pi d_I \rho}{A_I} \quad (24)$$

$$L_{hd} = \frac{4l_d \rho}{\pi d_d^2} \quad (25)$$

$$L_{hL} = \frac{4l_L \rho}{\pi d_b^2} \quad (26)$$

where  $\rho$  is the liquid density,  $d_I$  is the main diameter of track axial ring,  $A_I$  is cross-section surface,  $l_d$  and  $d_d$  are the track height and the decoupler diameter. Calculating hydraulic resistances of  $R_{hdP}$ ,  $R_{hd}$  takes more time than inductance. In addition to geometric calculations, resistance depends on the fluid viscosity and current type. For instance, the current within inertia track can be stimulated by moderate flow (Reynolds Number  $\ll 2300$ ). The liquid flowing from chambers to inside and outside inertia track can be stimulated through (Orifice) current of pore. Similarly, the liquid flow in inertia track between pore surfaces (Orifice) and decoupler is simplified with (Orifice) current of pore. In order to Figure out hydraulic resistance, the following equations are used:

$$R_{hdp} = 024 \frac{\rho v^{0.25} l_{dp}}{d_{dp}^{4.75}} \quad (27)$$

$$R_{hl} = \frac{128 \pi d_1 \mu}{A_I} + R_{hli} + R_{hlo} \quad (28)$$

$$R_{hd} = C_d l_d \pi d_d \sqrt{\frac{\rho}{2}} \quad (29)$$

$$R_{hli} = R_{hlo} = C_d A_I \sqrt{\frac{\rho}{2}} \quad (30)$$

In equations (27) to (30),  $v$  and  $\mu$  are the liquid absolute viscosity and kinematic coefficient.  $C_d$  is discharge coefficient,  $l_{dp}$  and  $d_{dp}$  are length and diameter of resistant piston.

According to balance of the original coordinates – chassis as the fixed frame – and if all sentences related to pressure are removed from equations (12) to (19), then we will have the equations below for engine mount:

$$m_r \ddot{x}_r + b_r \dot{x}_r + \left( k_r + \frac{A_r^2}{c_{u1}} \right) x_r - \frac{A_r}{c_{u1}} V = F(t) \quad (31)$$

$$L_{hu} \dot{Q}_u + R_{hdp} Q_u + \left( \frac{1}{c_{u1}} + \frac{1}{c_{u2}} \right) V_u = \frac{A_r}{c_{u1}} x_r + \frac{1}{c_{u2}} (V_I + V_d) \quad (32)$$

$$L_{hl} \dot{Q}_I + R_{hl} Q_I + \left( \frac{1}{c_{u2}} + \frac{1}{c_{L1}} \right) V_I = \frac{A_L}{c_{L1}} - \left( \frac{1}{c_{u2}} + \frac{1}{c_{L1}} \right) V_d \quad (33)$$

$$L_{hL} \dot{Q}_L \left( \frac{1}{c_{L2}} + \frac{1}{c_{L1}} \right) V_L = \frac{V_I + V_d}{c_{L1}} \quad (34)$$

Equations (31) to (34) illustrate the principles which can be used in passive hydraulic engine mount.

## 10. Conclusions

The principal results from presentation such implications as advantages and disadvantages of various types of engines mount with capability in the vehicles including elastomeric engines mount, hydraulic engines mount (with inertia track, inertia track and decoupler, inertia track and decoupler and piston), semi/half-active engines mount, in relation to each other, as well as the results from studying and comparing them detect that today, using hydraulic engines mount in the vehicles is optimum in terms of costs and

efficiency for the present demand. Furthermore, as to the vastness and expanse of arrangement of 3-point method in the present engines mount is easily available by changing into semi- and active models to increase the level of comfort and convenience for the passengers in special automobiles. The rest of the present paper deals with the conditions for general function of vehicle engines mount such as p and boundary diagram, frequency functional ranges, common types of engines mount positioning system, structure, and base of hydraulic engines mount function. As discussed throughout the paper, such classification, and introducing it can indicate the most significant functional features of this part.

**Nomenclature**

$Q_u(t)$	=	Flow through the upper chamber	$l_L$	=	Height of lower chambers in balanced status (at equilibrium)
$Q_L(t)$	=	Flow through the lower chamber	$d_b$	=	Diameter of undermost rubber
$Q_I(t)$	=	Flow through the inertia track	$t_b$	=	Thickness of undermost rubber
$Q_d(t)$	=	Flow through the decoupler	$C_{hd}$	=	Equivalent capacity of the decoupler fluid module
$Q_s(t)$	=	Flow due to the chassis movement	$B_f$	=	Equivalent capacity of the Bulk fluid module
$P_{u1}$	=	Pressure in the bell chamber	$d_I$	=	Main diameter of track axial ring
$P_{u2}$	=	Pressure in the upper chamber	$A_I$	=	Cross-section surface
$P_{L1}$	=	Pressure in the top of lower chamber	$l_d$	=	Decoupler height
$P_{L2}$	=	Pressure in the bottom of lower chamber	$d_d$	=	Decoupler diameter
$A_r$	=	Primary area of main rubber	$C_d$	=	Decoupler hydraulic capacity
$k_r$	=	Shearing stiffness of main rubber	$l_{dp}$	=	Length of piston movement
$b_r$	=	Damping coefficient of main rubber	$d_{dp}$	=	Diameter of piston
$m_r$	=	Mass of main rubber	$R_{hdp}$	=	Hydraulic resistances of the piston
$C_{u1}$	=	Hydraulic capacities in the upper chamber (includes piston rubber with liquid)	$R_{hd}$	=	Hydraulic resistances of the decoupler
$C_{u2}$	=	Hydraulic capacities in the upper chamber (includes decoupler with liquid)	$R_{hI}$	=	Hydraulic resistances of the inertia track
$C_{L1}$	=	Hydraulic capacities in the lower chamber (include the top of undermost rubber with fluid)	$y(t)$	=	Movement of the vehicle's body
$C_{L2}$	=	Hydraulic capacities in the lower chamber (include the bottom of undermost rubber with fluid)	$\omega_{dr}$	=	Stimulation frequency
$L_{hu}$	=	Fluid hydraulic inductance in the upper chamber	$\xi$	=	Decoupler Coefficient without aspect
$L_{hI}$	=	Fluid hydraulic inductance in the inertia track	$Z_r$	=	Road equation
$L_{hd}$	=	Fluid hydraulic inductance in the decoupler	$\omega$	=	Angular frequency
$L_{hL}$	=	Fluid hydraulic inductance in the lower chamber	$V$	=	Vehicle velocity
$x_c$	=	Mass displacement of the chassis	$F_o$	=	Power reached to engine is represented
$x_r$	=	Mass displacement of the upper compliance	$F_t$	=	The incoming power through vehicle body to engine mount
$F(t)$	=	Excitation force coming from the engine			
$l_r$	=	Thickness of the piston rubber as a standing cylinder			
$\nu$	=	Ratio of Poisson module			
$\mu$	=	Liquid absolute kinematic coefficient			
$E_r$	=	Young's rubber module			
$l_u$	=	Height of upper chambers in			

## References

- [1] G. Genta and L. Morello, "System Design," in the automotive chassis, Springer, 2008.
- [2] J. C. Dixon, Suspension geometry and computation, Wiley., 2009.
- [3] R. Jazar, "Theory and Application," in Vehicle Dynamics, Springer, 2008, pp. 931-975.
- [4] J. Marzbanrad and M. A. Babalooei, "Grazing Bifurcations And Chaos Of A Hydraulic engine moun," International Journal of Automotive Engineering, vol. 6, no. 2008-9899, 2016.
- [5] R. M. Brach and A. Haddow, "dynamic response of Hydraulic engine mount ," SAE Technical Paper, no. 931321, 1993.
- [6] F. G. a. R. Nakhaie, "Development and Analysis of a Simplified Nonlinear Model of a Hydraulic engine mount," Vibration and Control, 2000.
- [7] S. B. Purohit, S. R. Lapalikar and V. Jain, "Effect of road profile and curves generated by wheel on the performance of a shock absorber of a motorcycle," Indian Journal of Science and Technology, vol. 4, no. 5, 2011.
- [8] T. Feyzi, M. Esfahanian, R. Tikani and S. Ziaei-Rad, "Simulation Of The Dynamic Behavior Of The Magneto-rheological engine mount For Automotive Applications," International Journal of Automotive Engineering, vol. 1, no. 2, 2011.
- [9] A. Moran and M. Nagai, "Optimal active control of nonlinear vehicle suspensions using neural networks," JSME international journal, Ser. C, Dynamics, control, robotics, design and manufacturing, vol. 37, pp. 707-718, 1994.
- [10] D. Vetturi, M. Gadola, D. Cambiaghi and L. a. Manzo, "Semi-active strategies for racing car suspension control," SAE Technical Paper, no. 962553., 1996.
- [11] B. Sakhaei and M. Durali, "Vehicle Interior Vibration Simulation-a Tool For engine mount Optimization," International Journal of Automotive Engineering, vol. 3, no. 4, 2013.
- [12] G. Kim and R. Singh, "A Study of Passive and Adaptive Hydraulic engine mount Systems," Journal of Sound and Vibration, 1995.
- [13] J. Campos, L. Davis, F. L. Lewis, S. Ikenaga, S. Scully and M. Evans, "Active suspension control of ground vehicle heave and pitch motions," In the 7<sup>th</sup> IEEE Mediterranean Control Conference on Control and Automation, 1999.
- [14] S. Ikenaga, F. L. Lewis, J. Campos and L. Davis, "Active suspension control of ground vehicle based on a full-vehicle model," in *American Control Conference*, 2000.
- [15] Y. Rasekhipour and A. Ohadi, "A Study On Performance Of Simplified Vehicle Models In Optimization Of Hydraulic engine mount In Comparison With Full-Vehicle Model," *International Journal of Automotive Engineering*, vol. 1, no. 2, 2011.
- [16] W. B. Shangguan and L. Z. H, "Modelling of a Hydraulic engine mount with fluid-structure interaction finite element analysis," *Journal of Sound and Vibration*, 2004.
- [17] H. Adiguna, M. Tiwari, R. Singh and D. Hovat, "Transient Response of a Hydraulic engine mount," *Journal of Sound and Vibration*, 2003.
- [18] A. Geisberger, A. Khajepour and F. Golnaraghi, "Non-linear Modeling of Hydraulic engine mount : Theory and Experiment," *Journal of Sound and Vibration*, 2002.
- [19] F. Svahn, J. Jerrelind and H. Dankowicz, "Suppression of bumpstop instabilities in a quarter-car mode," Springer Berlin Heidelberg, 2010, pp. 137-147.
- [20] J. Colgate, T. Chang, C. Chiou, K. Liu and M. Kerr, "odelling of a Hydraulic engine mount focusing on response to sinusoidal and composite excitations," *Journal of Sound and Vibration*, no. 184, pp. 503-528, 1995.
- [21] S. Liu, Z. Shijian, Y. Qingchao and H. Qiwei, "Study on the identification of experimental chaotic vibration signal for nonlinear vibration isolation system," *Journal of Computational and Nonlinear Dynamics*, vol. 6, pp. 041006-041006, 2011.
- [22] M. Siewe, "Resonance, stability and period-doubling bifurcation of a quarter-car model excited by the road surface profile," *Physics Letters A*, vol. 374, pp. 1469-1476, 2010.