

Cost and Effectiveness Study of Hybrid Electric Vehicle Technologies Based on China Data

Zongwei Liu, Tianze Shi, Kangda Chen, Han Hao, Fuquan Zhao*

(Tsinghua Automotive Strategy Research Institute, State Key Laboratory of Automotive Safety and Energy, Tsinghua University, Beijing, 100084)

Abstract

Energy conservation and emission reduction has become increasingly significant for automobiles under the severe energy situation. Hybrid electric vehicle (HEV) technology is one of the most promising solutions. In this study, structures and features of current mainstream hybrid powertrains are classified and illustrated respectively. 30 representative HEV models have been acquired by going through HEV list in the bulletin released by Ministry of Industry and Information Technology of China (MIIT), and the effectiveness of fuel consumption reduction data are also acquired. Based on the basic cost data of EPA, a cost analysis is applied to estimate the incremental cost of those 30 HEVs in China respectively. Further, comparative analysis and comprehensive assessment of cost, and cost effectiveness fuel consumption reduction are processed for each hybrid system. Assessments of the application and the future developing direction for each hybrid system are made.

Keywords: Hybrid Electric Vehicle; Technology Rout Decision; Fuel Consumption Reduction; Cost; Cost Effectiveness

1. Introduction

The global energy and environment situation is increasingly severe. Various countries are seeking technology breakthroughs to address issues of large energy consumption in transportation sector. Hybrid electric vehicle (HEV) technology is one of the most promising solutions. In Europe, countries such as Norway, announced that sales of internal combustion engine vehicles (ICEV) will be halted in 2025; Germany, as a major manufacturer in traditional vehicles, also puts forward a plan for halting sales of ICEV in 2030. Japan has always been taking the lead in energy conservation, and Toyota announces production of fuel vehicles will be totally halted in 2050; Honda announces one-third of vehicles will be HEV or zero emission vehicles in 2030. Thus, shares of ICEV will decline gradually, and the gap will be filled up by other types of vehicles. As it would be a long-term process for electric vehicles (EV) and fuel cell vehicles (FCV) to be widespread in popularization and, HEV will be prevailing in the market instead.

The Chinese government has paid high attention to energy issues. In 2015, China's petroleum import dependency has reached 60.6%, which is much higher

than the internationally recognized safety degree of 50%. Fuel consumption regulations (FCR) in China have become more stringent. The phase IV FCR in China has been defined as 5L/100km, and 4L/100km in phase V has been involved in the China Industry 2025. The fuel consumption regulation in phase VI is still being under discussion, and the value might be defined as 3.2L/100km or even lower. Whichever the result it is, the value will be reputed as a rather stringent regulation for automotive makers. In this context, low carbon has become an irresistible trend for the development of automotive technologies.

2 Analysis on the necessity of HEV technologies

2.1 Fuel consumption regulations and HEV technologies in China

Viewing the development process of China fuel consumption regulations, it can be found that proportions of fuel consumption target limits reduction are different in each mass range of vehicles, featuring more sharply in large-sized vehicles, and less sharply in small-sized vehicles, and reflecting the trend of restricting large-sized vehicles and promoting small-

sized ones. As the average curb weight is decreasing stepwise on the whole, the scale-up of small-sized vehicles will be more conducive to achieve energy conservation. The detailed standard rules of phase V FCR have not been introduced yet, however, a draft version is under discussion which indicates that each mass range will be declined roughly in equal proportion. If this draft plan is defined to be implemented, fuel consumption limits for all the small-sized vehicles will be decreased to 3.3L/100km or even below. In this case, merely depending on internal combustion engine (ICE) will be rather difficult to meet the FCR requirements. Thus, small-sized vehicles in the future will be oriented to be EVs, while large and mid-sized vehicles will tend to be HEVs. From this perspective, hybrid power is not a kind of option, but a required technology. The issue merely lies in how to select a more suitable plan for manufacturers. Automobile manufacturers in Japan, the U.S., Europe, Korea and China have constantly introduced various types of HEV models recently, indicating hybrid power has been reputed as one of the most crucial means to meet the fuel consumption regulations.

2.2 Analysis on corporate technological decision-making

Technology route decision-making is an intricate systematic engineering for corporates, with multiple factors to be considered (Fig. 1). Automobile manufacturers must meet the requirements of current FCRs, and prepare for further upgrade of FCRs. The same requirements of FCRs can be satisfied by adopting different technology routes, which are with different incremental costs and effectiveness of fuel consumption (FC) reduction. Cost acceptable degree by the market should also be sufficiently considered, or it is meaningless for manufacturers if the customers

would not choose to pay for the products even though meeting the FCR. However, the factors such as regulations, cost, and market are intertwined and mutually affected. In brief, only when manufacturers comprehensively consider the cost input, effectiveness of fuel consumption reduction and energy-efficient potential of various technologies, can they make the best optimized selection of technology route.

HEV that involves two sets of mutually matched powertrains, is an intricate technology. There have been multiple hybrid systems with different structures. Each structure is with different cost performance and effectiveness in fuel consumption reduction. For automotive manufacturers, it is difficult to scientifically and effectively select a hybrid power technology plan. In this study, mainstream HEV structures have been systematically classified. A quantitative analysis and comparison of HEV models in Chinese market is made. The study is based on the data screened from official organizations. Combining the effectiveness of fuel consumption reduction and cost analysis that extends the EPA research, conclusions with reference value is achieved for manufactures to make HEV technology decisions.

2 Structure Analysis

2.1 Definition of degree of hybridization (DOH)

According to the calibration method for DOH of HEV by the Chinese National Standards, definition of DOH refers to the rated power of motor/ (rated power of motor + rated power of engine). The specific ranges are as follows:

- (1) Micro hybrid: $DOH < 10\%$
- (2) Mild hybrid: $10\% < DOH < 30\%$
- (3) Full hybrid: $DOH > 30\%$

DOH essentially represents the proportion of electric energy in HEV. Therefore, there is a positive correlation relationship between DOH and FC reduction effectiveness, which is a crucial reference index in this study.

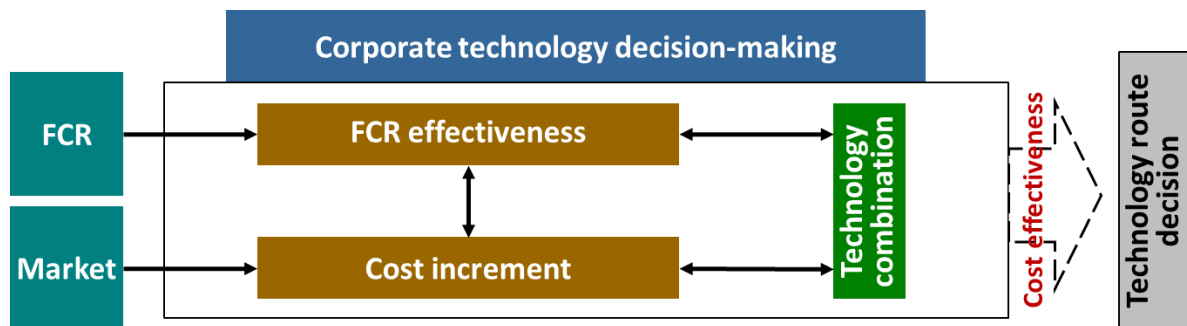

Fig1. Corporate technology route decision-making

2.2 Compiling of major hybrid power technologies

The current major hybrid technologies for industrialized application include start-stop (SS), belt-driven starter generator (BSG), clutch parallel system (motors are typically placed between the engine and transmission, thus is also called a P2 system), and planetary gear set (also called power split system, PS), bi-motor series-parallel system (SP), as presented in Table 1. Recently some OEMs have introduced 48V mild hybrid system, which is not an independent hybrid power structures, but mostly adopts BSG mild hybrid structure. This structure draw much attention recently, thus is listed separately is Table 1. Major HEV systems are listed as follows.

The plug-in hybrid power technology is not involved in this study. Comparing with the conventional hybrid power technologies, the size of battery mounted in the plug-in hybrid electric vehicles (PHEV) is larger than those in HEVs to support longer extended electric drive range. The control system, working condition, control logic and principle of fuel consumption reduction are remarkably different from conventional HEVs. In addition, PHEV is classified into the category of New energy vehicles (NEV) in China, benefiting from preferential policies that are different from conventional HEV, and will affect technology cost and market acceptance. Therefore, plug-in hybrid power technology is not considered in the analysis of HEV technologies in this paper.

From the perspective of structure, serial hybrid system is not listed in the study either. In terms of series hybrid power system, electric motor is totally in charge of power drive, while engine merely functions as electricity generation, featuring limited hybrid flexibility. The series hybrid power system is mainly applied to large-sized buses and plug-in hybrid passenger cars, and it is less adopted in conventional hybrid passenger cars. Thus, it is not involved in the contrastive analysis.

2.3 Analysis of Major HEV System Structures

(1) Start-stop (SS)

The start-stop merely updates the starting dynamo, and is consisted of enhanced starting motor and conventional alternator (Fig.2). It features lower cost and less modification for the applying, but with poorer FC reduction effectiveness.

(2) Belt-driven starter generator (BSG)

BSG adopts a larger alternator for power supply and energy regeneration, which is connected to the

engine by a belt, as in Fig.3. The structure is relatively simple, featuring less modification and less overall cost for applying. In terms of FC reduction effectiveness, it is better than the SS, but still unfavorable.

(3) Parallel hybrid system

Parallel HEV has two sets of power systems of motor and engine, which can respectively drive the vehicle and coordinate with each other, namely, realizing the functions of “motor drive”, “engine drive” and “engine + motor collaborative drive”. According to the different rated power of drive motors, the clutched parallel systems enable different DOHs from mild hybrid to full hybrid.

According to the position of motors in hybrid systems, they are differently classified: P1 (Position 1) refers to motor before engine; P2 (Position 2) refers to motor behind engine, but before transmission; P3 (Position 3) refers to motor behind transmission; P4 (Position 4) refers to motor on drive shaft, such as wheel hub motor. As in parallel hybrid systems the drive motor is generally situated in P2, it is also called P2 structure. Typical parallel hybrid systems are shown in Fig. 4, in which type (a) is a commonly used parallel system by major OEMs. The dynamic coupling of engine and motor is achieved by clutch, featuring high transmission efficiency and definite control logic. As for type (b), motor and engine are directly connected, featuring simple and compact. However, the possibility of motor reverse towing the rotation of engine results in lower system efficiency, while the shake of clutch disengagement/engagement may be prevented in this structure.

(4) Planetary gear set hybrid

Automobile manufacturers, represented by Toyota, use planetary gear as dynamic coupling mechanism. According to operating features, the design is also called power split (PS) system. With relatively high cost, the structure features flexible power distribution, and favorable FC reduction effectiveness. Besides, the technologies are almost patent-monopolized by Toyota Motor. Other OEMs have to adopt intricate structures like double-row planetary gears to realize the similar functions, which further increases development difficulty and application cost.

The major applications of PS structures include Toyota THS, Ford FHS, GM AHS, and Geely CHS as in Fig.5. Except THS, the double-row planetary gear set is applied in all other systems..

Table 1 List of major HEV systems

Structures	Major functions	Applied range
SS	Idle start-stop Less brake power regeneration	Micro hybrid
BSG	Idle start-stop Brake power regeneration Power assist	Micro hybrid - mild hybrid
Clutched parallel system (P2)	More brake power regeneration Power assist Less battery electric driving	Mild hybrid - full hybrid
Planetary system (PS)	More brake power regeneration Power assist	Full hybrid
Series-parallel system (SP)	More power regeneration Power assist Less battery electric driving	Full hybrid
48V system	Idle start-stop Brake power regeneration Power assist	Micro hybrid - mild hybrid

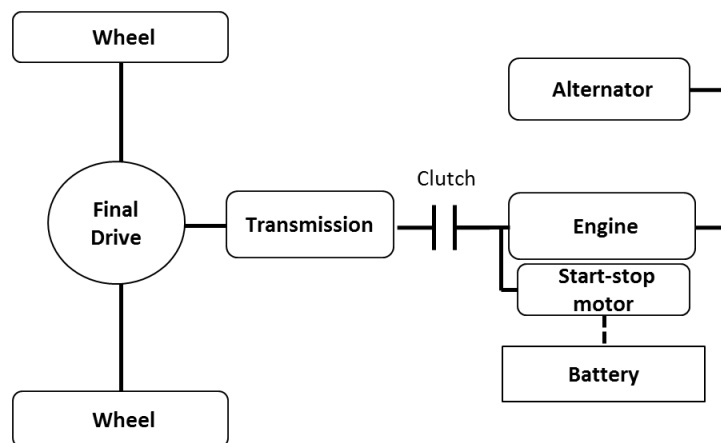

Fig2. Start-stop (SS)

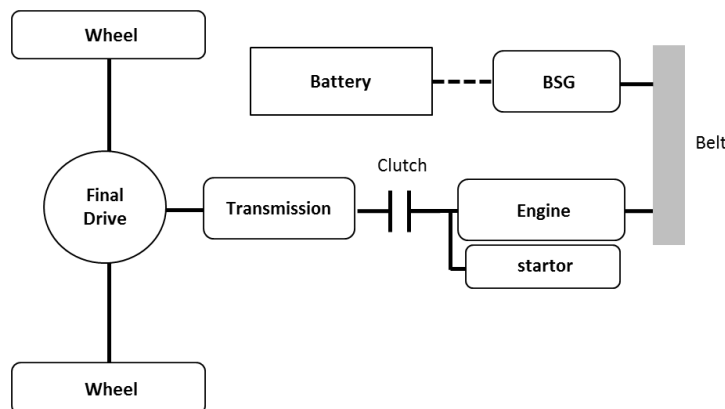

Fig3. BSG structure

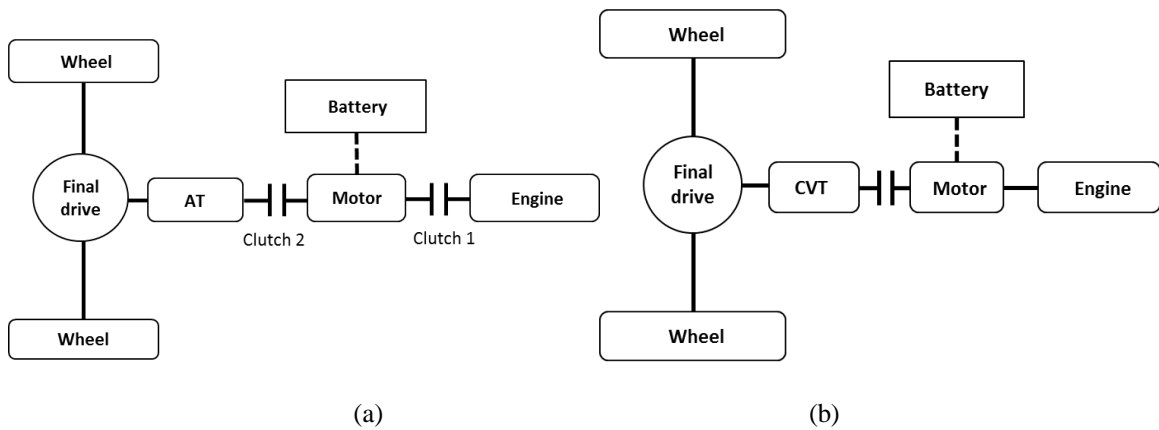

Fig4. Two structures of parallel HEV

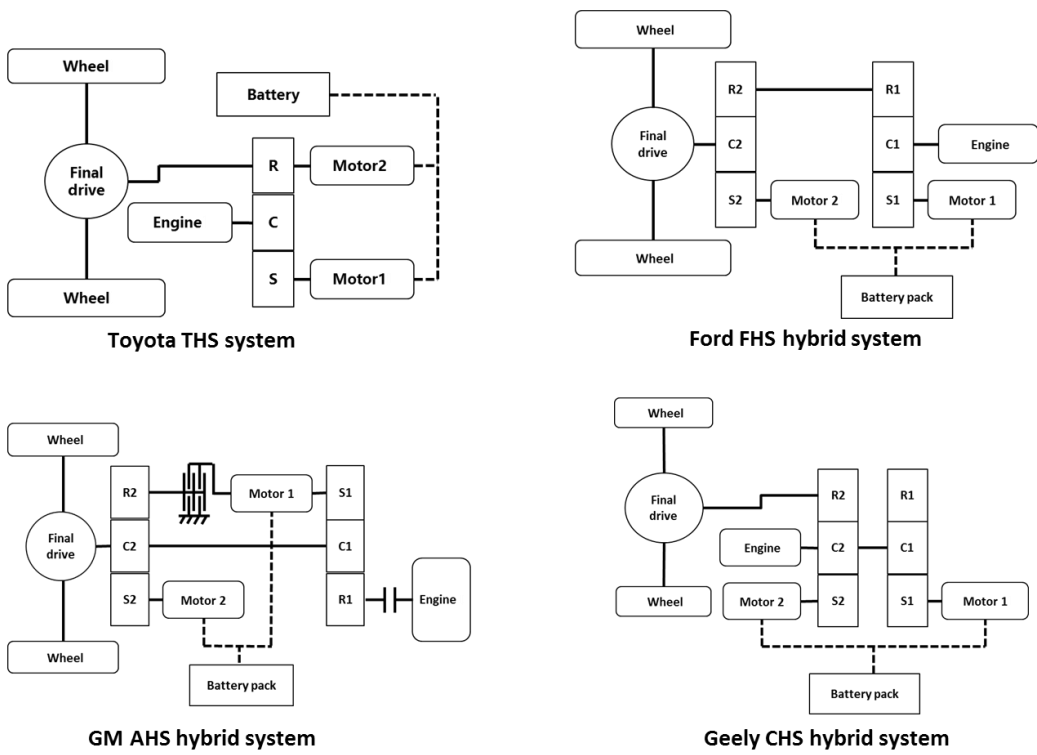

Fig5. PS structures

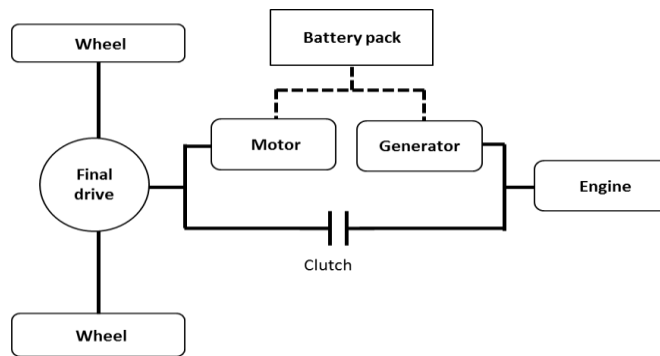

Fig6. SP hybrid system

(5) Series-parallel (SP)

Recently Honda has developed a new-type HEV system that applying clutch as coupling mechanism, which have the features of both serial system and parallel system. As presented in Fig.6, serial drive happens in the state of clutch disengagement; parallel drive happens in the state of clutch engagement. Flexibly allocate power output is achieved by applying different operating modes. According to its technical features, this system is called serial-parallel (SP) in this study.

(6) 48V system

The major OEMs in Europe currently introduced a 48V mild-hybrid system, mainly adopting BSG structure as in Fig.7. The power supply voltage of in-vehicle electrical system is improved to 48V, thus correspondingly increased peak load power for electrical components. BSG motor with higher power can be mounted to meet more functional demands. The performance becomes more superior and energy conservation could further be achieved.

48V system can also be achieved through other system, and further improves FC reduction effectiveness using P2 structure. However, it will bring about substantial variation of driveline, with higher cost. Few OEMs adopt other ways to achieve 48V system rather than BSG. Thus, the analysis of BSG can be reputed as a crucial reference for 48V system.

3 Acquisition of Fuel Consumption Data

In this analysis, more than 40,000 pieces of information concerning vehicles registered in MIIT since 2010 are surveyed, 155 HEV types are distinguished. In account of overlap of some HEV models (for instance, some OEMs introduce the upgrading versions of same model in different years; some OEMs release the same model with different configurations, which are classified by different types), the overlapped models should be removed. On the other hand, fuel consumption data of some models in early stage are not as valuable as references considering the rapid development of HEV technologies and fuel consumption regulations. To ensure the objectivity and representativeness of data, 155 types of HEV models should be further screened. The specific indexes are defined in this study:

- (1) Delete models in earlier stages and select HEV models since 2012 only
- (2) Merge the same models in different years
- (3) Merge the same models with different types

(4) Delete PHEV models

After adopting the screening indexes above, 30 types of models are finally applied to the research, and their parameter data is classified. The parameters of fuel consumption and curb weight are acquired from the MIIT data, and parameters such as structure, motor power, and engine power are obtained via available literature, network information gathering and field survey.

Besides HEV models, data of benchmarking vehicles, or ordinary vehicle models corresponding to HEV models should also be considered. Some HEV models directly correspond with ICE models, namely, one model is divided into ICE version and HEV version; some HEV models are developed particularly and do not directly correspond with ICE models. For the first case, ICE models can be directly selected as the benchmarking; for the second case, the models in the same series can be selected considering other parameters. In this study, degree of nearness of crucial information such as curb weight, engine type and transmission type are synthetically considered to ensure the accuracy of benchmarking as shown in Fig.8.

Automotive manufacturers tend to mount with other energy conservation technologies on the basis of original vehicles such as higher power rated engine and low-resistance technologies when developing HEV models. These technologies will affect the fuel consumption data. Thus the fuel consumption gap between HEV and its benchmarking models cannot be totally reputed as the contribution made by HEV. In this study, prudent selection for benchmarking vehicle models possibly reduce the impacts; the impacts indeed exist in different OEMs and vehicle models. Therefore, accuracy of comparison results is relatively reliable.

3 Acquisition of cost data

3.1 Introduction to cost analysis method

Incremental costs of HEV technologies can be acquired by cost analysis method, which can be divided into direct manufacturing cost (DMC) and indirect cost (IC) in specific tests. A set of basic data concerning incremental costs is acquired by dismantling the typical vehicle, and examining the cost increment on each automobile systems by the application of hybrid technologies. Then direct cost data for other vehicles models can be acquired by scaling the system cost increment according to the

specific situation of applied models based on the basic data. Indirect cost can be expressed by a coefficient and divided into two parts. Part I is the DMC related to production, while the part II is the IC unrelated to production. The coefficients of two parts are different. Both indirect cost and direct cost related to production shall be multiplied by learning curve, which represents the situation of cost reduction as time lapse and production mount increases. Finally, the total cost will be acquired by rolling up these data as shown in Fig.9.

3.2 Direct cost

Environmental Protection Agency (EPA) has released a research report in 2012 about a tear-down research done by dismantle the typical HEV, and examine the cost variation of systems, subsystems and assemblies, parts until the indivisibles components. Material cost, labor cost, equipment cost and other factors are considered to obtain the total DMC. The National Research Council (NRC) also applied the EPA data to conduct further research on fuel consumption reduction, which indicates high universality of the basic data and cost analysis method. In this study, the data of disassembly analysis report released by EPA is adopted as the basic data.

Analysis on the cost increment of each subsystem in tear-down research is processed could obtain where the largest increment happens. For example, cost increment of each subsystem and component of typical HEV with P2 structure are listed as in Fig.10. HEV technologies affect many systems in cost increment, among which driveline system and power supply system are most effected. Motors are added to driveline system and corresponding structural changes are caused, which increases incremental costs. Incremental costs of power supply system are mainly caused by the introduction of power battery.

EPA delegates FEV to process the rear-down research on typical vehicles with BSG structure, P2 structure and PS structure, and acquire basic data of HEV cost. With the basic data obtained by tear-down research, examine the major influence factors that causes the cost increment and then scale the basic data according to the influence factors variation. For instance, cost variation of driveline system is related to total output power and motor power, and that of power supply system related to battery capacity and motor power, and that of circuit layout are related to electrical system voltage and electric current. Scale all the

factors related, and thus obtain the cost variation of HEV technologies applied in different models. In this study, direct cost of the selected 30 types of HEV models in Chinese market has been estimated by referring to the methodology and basic data above.

3.3 Indirect cost and learning curve

The indirect cost of 30 types of HEV models has been estimated by adopting indirect cost multiplier (ICM) method put forward by EPA. According to innovation degree, the method is divided into 4 types, namely, "incremental innovation", "modular innovation", "structural innovation" and "differentiation innovation", corresponding to different ICM coefficients respectively. Indirect cost can be obtained by multiplying direct manufacturing cost by appropriate ICM coefficients. HEV technology belongs to the differentiation innovation with higher difficulty, and its ICM coefficient is larger than the conventional indirect cost coefficient 0.5.

Besides, as time goes on and accumulative production of products increases, technology application cost will decrease, which can be represented by learning curve. The learning curve can be divided into three types, namely, "steep curve", "flat curve" and "without learning curve". The "steep curve" represents new technology application, whose cost will sharply decline as time goes by; "flat curve" represents relatively mature technology application, whose cost will slowly decline; "without learning curve" represents no cost reduction space for the technology. For HEV technology, "steep curve" is suitable for the representation of battery belonging to relatively new technology and "flat curve" suits for the representation of other mechanical parts belonging to relatively mature technologies.

3.4 Overview of final data

Respectively test the incremental direct and indirect costs according to the above methods, and finally obtained the incremental cost data of the 30 types of HEV models in Chinese market mentioned in Section 3.1. All the data are compiled as presented in Table 2 below.

Notes*: As SP structure has not been listed in the official data of MIIT yet, the data are selected from authoritative figures of the corresponding models in the U.S. market.

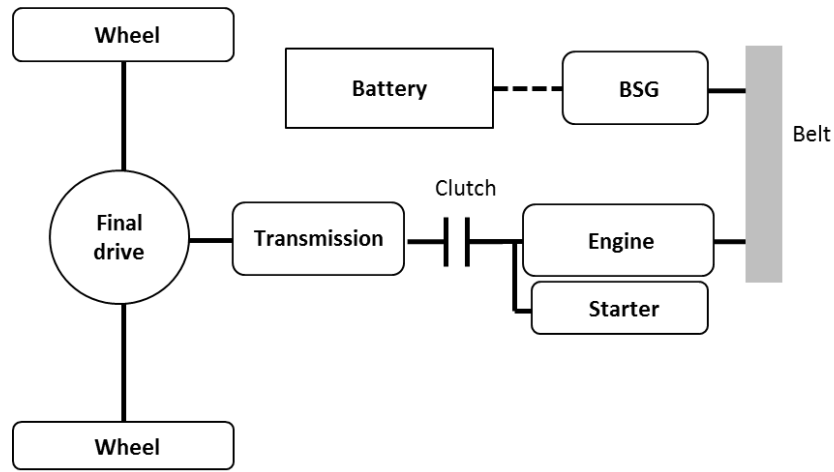

Fig7. Typical structure of 48V

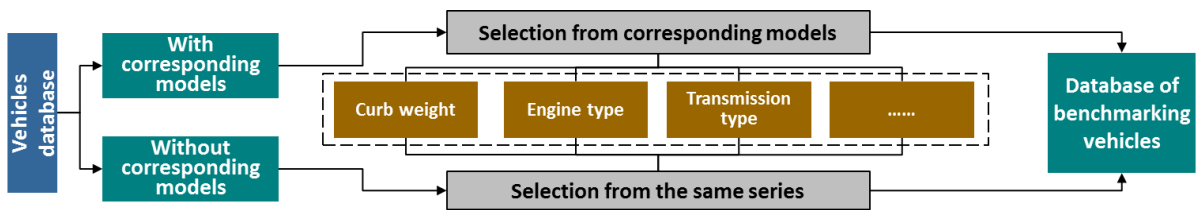

Fig8. Select of benchmarking models

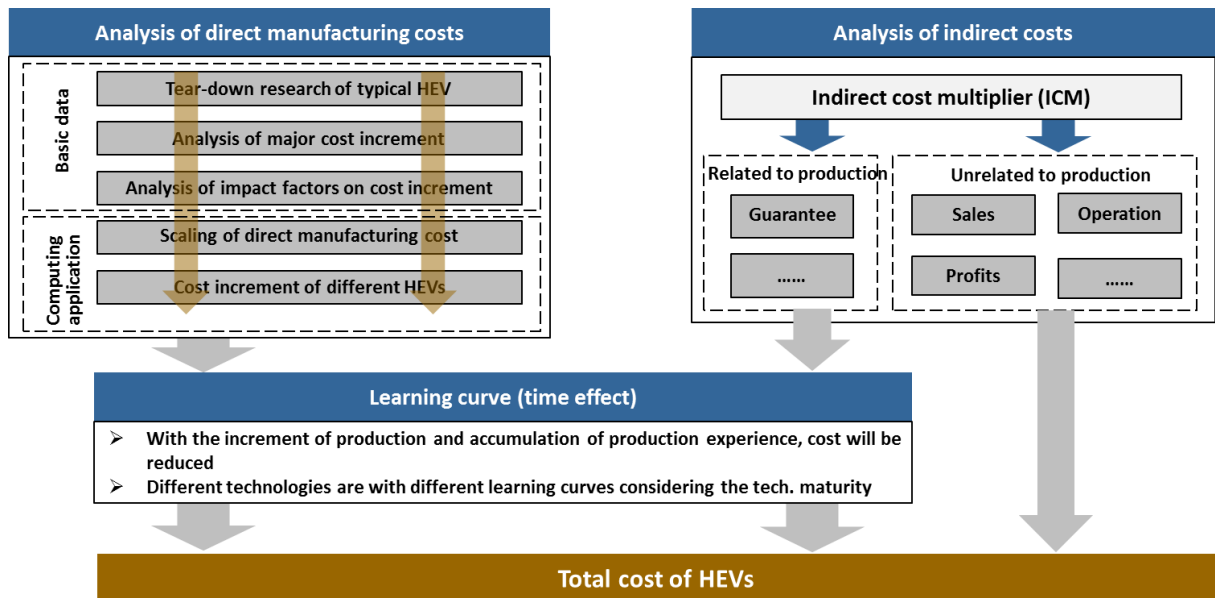

Fig9. Cost calculation flow

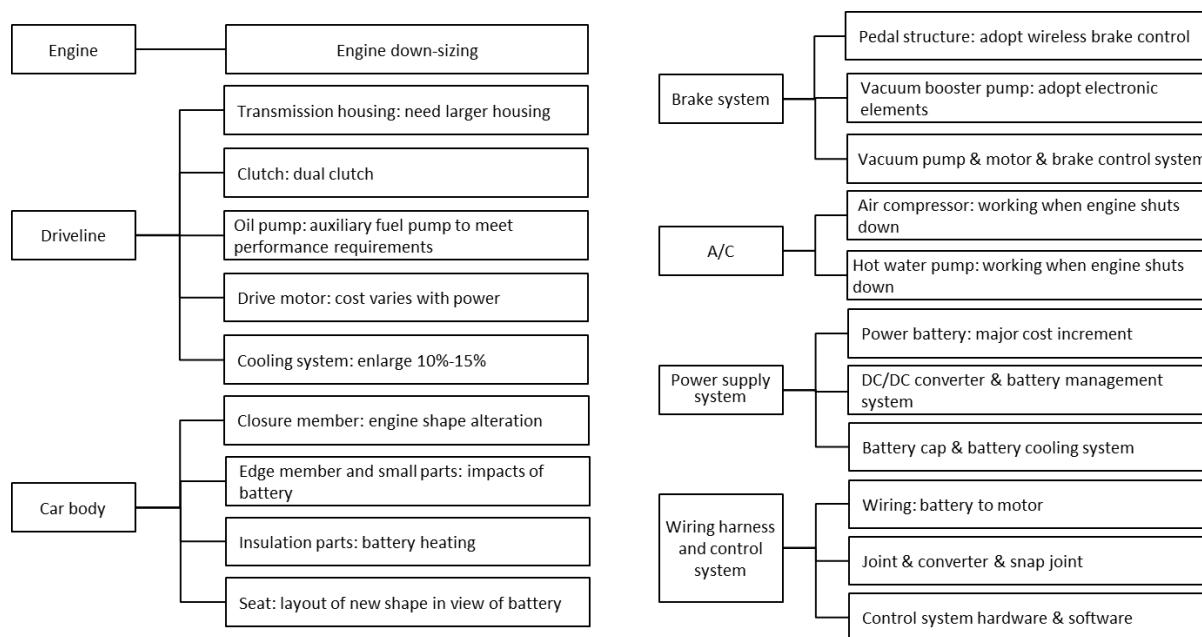

Fig10. Cost growth points of typical P2 hybrid power

5 Results and Analysis

5.1 Analysis of Fuel Consumption Reduction

According to the data of HEV models above, a comparative analysis of different HEV models is made. Relationship between fuel consumption reduction effectiveness of HEV and DOH is presented in Fig.11. Fuel consumption reduction effectiveness is calculated by the formula below.

$$E = \frac{B - H}{B}$$

Where E- FC reduction effectiveness, H – fuel consumption of HEV model, B – fuel consumption of benchmarking vehicles.

Effectiveness of fuel consumption reduction is positively related to DOH. With the increasing of DOH, FC reduction effectiveness accordingly improves. However, they are not in linear relationship. When the DOH is higher, the improvement of corresponding fuel consumption reduction is not as effective. Fitting analysis is processed with the base data, it is found that a logarithmic relationship can be obtained between FC reduction and DOH, as follows:

$$y=0.0944 \ln(x)+0.3918$$

where y- FC reduction effectiveness, x- DOH.

In Fig. 11, The green zone, red zone and yellow zone in the diagram represent the envelop circles of SS+BSG, P2, and PS structures of relevant hybrid vehicle data respectively. These data showed a

Table 2 Cost and FC reduction effectiveness data of 30 HEV models

distinction with the ranges of micro hybrid, mil hybrid and full hybrid. It should be noted that as previously mentioned, data of D1 model in Table 2, or SP structure have not been listed in the official data of MIIT yet, the relevant data representation in the U.S. is taken for reference. There are two scatter points in the discrete intervals with the reason being marked in the figure, which are not involved in analysis.

5.2 Analysis of cost effectiveness

The cost effectiveness study actually refers to cost performance, defined by the fuel consumption reduction effectiveness and incremental costs, and expressed by the improvement of FC reduction per 1,000 CNY cost investment. The higher value of result indicates better cost effectiveness of corresponding technologies, namely with higher cost performance value. The overall relationship between cost effectiveness and total FC reduction effectiveness is presented in Fig.12. As is shown in the figure, the cost effectiveness curve is roughly in concert with the trend of histogram of FC reduction effectiveness. It means that the cost effectiveness increases with the increasing of cost. Despite the fluctuation of several data, general trend of the relationship is still reliable. Thus for HEV models with better total FC reduction effectiveness, the better cost effectiveness will be acquired, but at the expense of higher considering the total cost input.

Structure	Model code	DOH	Fuel consumption /L/100km	Fuel consumption of benchmarking vehicles/L/100km	FC reduction effectiveness	Total incremental cost/CNY
Mild hybrid	A1	0.043	5.8	6.3	8%	3,180.7
	A2	0.0769	8	8.4	5%	17,075.2
	A3	0.0769	8	10	20%	19,239.8
	A4	0.1005	7.2	8.6	16%	17,075.2
P2	B1	0.1455	7.5	8.9	16%	36,611.0
	B2	0.1509	6.2	8.2	24%	40,328.0
	B3	0.153	7.3	8.7	16%	31,236.0
	B4	0.1075	4.8	6.8	29%	35,166.2
	B5	0.1333	4.7	6.8	31%	31,279.3
	B6	0.1333	4.4	6.8	35%	28,128.7
	B7	0.2019	4.8	7.6	37%	34,274.1
	B8	0.2222	9.2	11.2	18%	35,168.7
	B9	0.4196	7.5	8.6	13%	33,023.3
	B10	0.14	6.5	10.7	39%	34,727.6
	B11	0.2414	5.4	7.4	27%	25,865.1
	B12	0.1859	7.3	9.8	26%	26,359.7
	B13	0.2414	5.4	7.6	29%	26,601.8
	B14	0.1925	5.4	6.5	17%	27,487.4
	B15	0.4196	7.5	8.6	13%	39,889.8
	B16	0.1724	7.6	10	24%	34,195.5
PS	C1	0.112	10	12.7	21%	35,218.4
	C2	0.4061	6.7	9.9	32%	37,945.4
	C3	0.4206	4.2	6.1	31%	28,843.8
	C4	0.4511	4.5	6.1	26%	29,471.3
	C5	0.4511	4.3	6.1	30%	29,383.3
	C6	0.4709	5.4	7.9	32%	34,566.3
	C7	0.4709	5.3	7.8	32%	33,818.3
	C8	0.389	6.7	8.8	24%	39,234.9
	C9	0.319	11.2	16.2	31%	43,588.0
SP*	D1	0.541	5.0	7.8	36%	36,334.7

5.3 Contrastive analysis of different structures

Comparison analysis of BSG, P2, PS and SP structures of HEV will be made following, which can be referred by automotive manufacturers in HEV technology route decision-making.

The diagram of FC reduction effectiveness, cost effectiveness and DOH is presented in Fig.13. The different colored blocks roughly represent the intervals of DOH, FC reduction effectiveness and cost effectiveness of different structures of models. Both FC reduction effectiveness and cost effectiveness showed a ordered relationship among those HEV structures which are: $BSG < P2 < PS < SP$.

The FC reduction effectiveness data of SP structure is obtained from the EPA, US data, which is different from the data of other models that is from MIIT, China. Considering the indirect reference value, it is marked in imaginary line as in Fig.13. To further confirm the reliability of research results, 15 types of HEV models with different structures in the U.S. market are selected and made comparison analysis with same analytical methods, as is presented in Fig.14 and Fig.15. In terms of FC reduction effectiveness, overall trend of models in the U.S. and China is similar, as $BSG < P2 < PS < SP$. It is noted that the FC reduction effectiveness of HEV models in the U.S. highlights better performance. The reason for the differences lie in different test conditions of China and US. The HEV technology would show more FC improvement in the U.S. condition in which more transient state occurs. In terms of cost effectiveness, the difference between China and US data lies in SP, which is slightly lower than PS, but slightly higher than P2 in US data. The cost effectiveness sequence is $BSG < P2 < SP < PS$. As there is only one type of model with SP structure data, further study is still needed.

An overall analysis of Fig.13 - Fig.15 is processed to obtain following conclusions:

BSG structure (including 48V system): This is a short-term plan. To achieve a certain degree of FC reduction effectiveness by less total cost can be a short-term plan for manufacturers with insufficient technologies. However, it features limited fuel consumption potential and less improvement space in future. In the long-term, manufacturers will have to develop new technologies subsequently to meet the more strict fuel consumption regulations. Beside, despite the total cost investment is relatively low, cost effectiveness of BSG is very poor actually. In addition, it should be figured out that the 48V system is mostly based on the BSG structure, thus conclusions above-mentioned is also applicable for 48V system, namely 48V system is more of a short-termed plan.

P2 and PS structure: These two structures are the mainstream HEV technologies. Both of them are with favorable performance in FC reduction effectiveness, total cost input and cost effectiveness. DOH of P2 structure mainly concentrates in mild hybrid range, while that of PS structure concentrates in full hybrid range. The distribution of P2 and PS structures results in FC reduction effectiveness of P2 structure is typically lower than that of PS structure. In terms of cost effectiveness, the data of both China and the U.S. indicate that of P2 is slightly lower than that of PS. P2 structure has been applied to more vehicles by automobile manufacturers in the world currently, while the OEMs applying the PS structure must try to evading the patent barrier of automobile manufacturers such as Toyota in PS structure.

SP structure: This structure adopted a new design and evaded the patent barrier of PS structure. An extraordinary FC reduction effectiveness may be acquired, even outpacing PS structure, based on the data in this paper. So this structure deserves more concerns. View from the research results of the U.S. data, cost effectiveness of SP is slightly lower than that of PS. However, considering the total FC reduction effectiveness, the total cost of SP structure is still relatively high to obtain the best FC reduction result. The intricate structure and high requirements for motor are the biggest challenges in cost reduction of SP structure. As for there is only one model of SP structure which is presented by Honda, the reference value is not as strong, and further studies on SP structure should be conducted. When facing more stringent phase V and VI FCR in the future, manufacturers should consider the remarkable superiority in FC reduction effectiveness of SP technology as a crucial technical option.

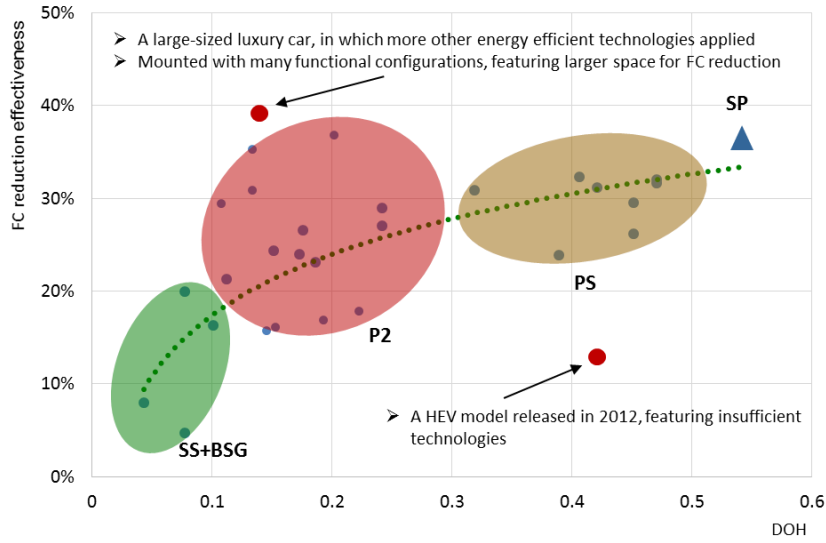

Fig11. Diagram of FC reduction effectiveness and DOH

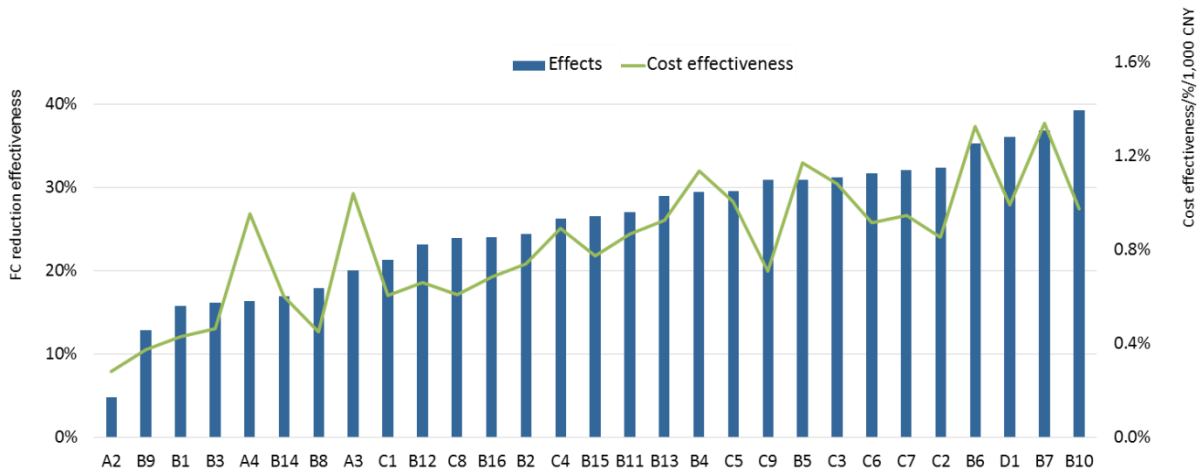

Fig12. Correlation between cost effectiveness and FC reduction effectiveness

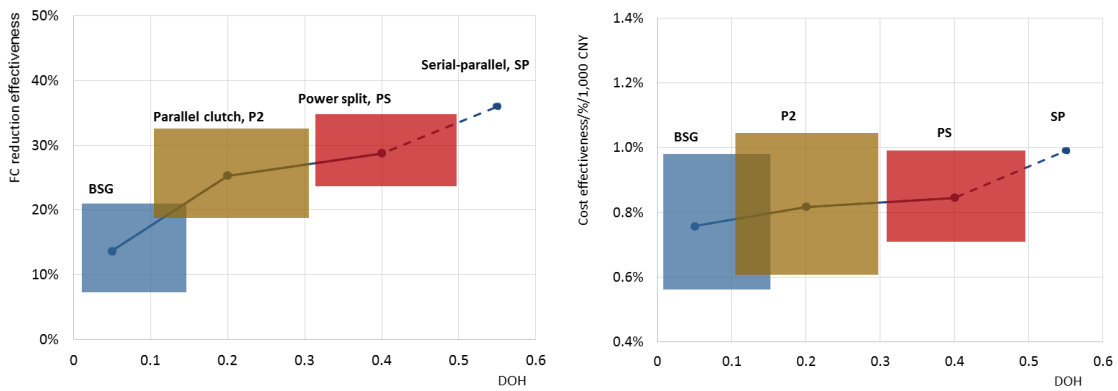

Fig13. Analysis of hybrid power technology structures

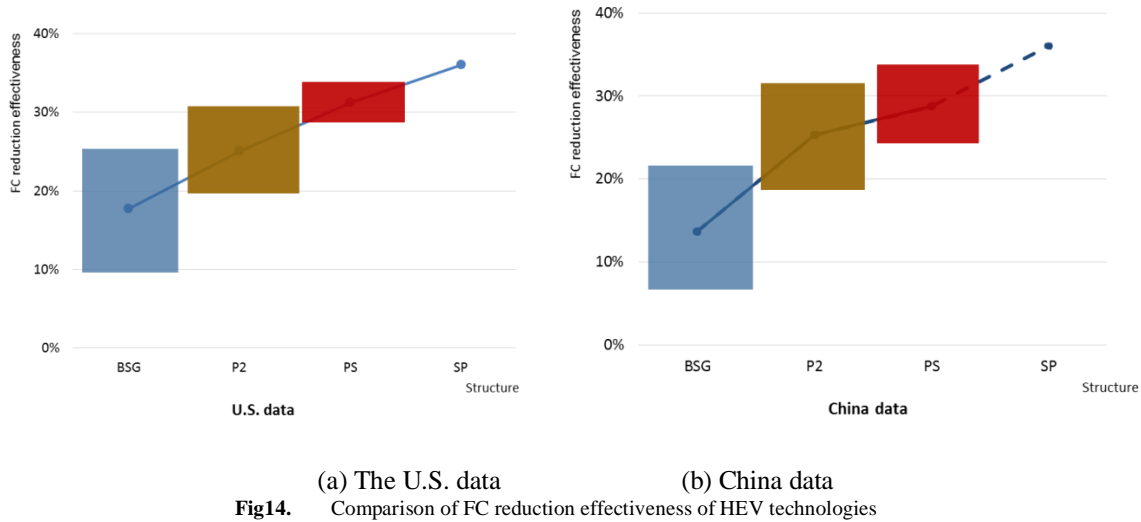

Fig14. Comparison of FC reduction effectiveness of HEV technologies

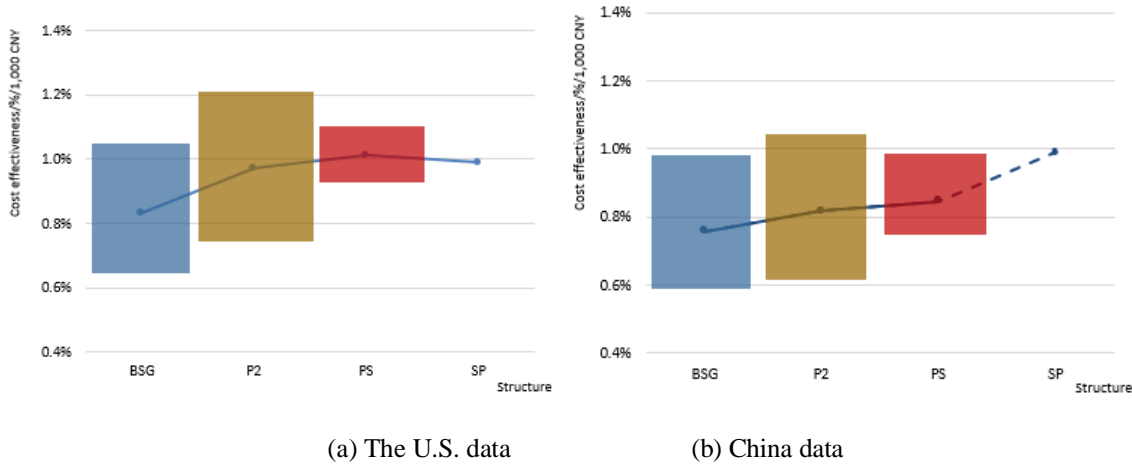

Fig15. Comparison of cost effectiveness of HEV technologies

5 Conclusion

In this paper, several different HEV technologies are analyzed, including classification, data acquisition and quantitative analysis of different technologies. Comparative studies of HEV technologies with different structures have been made considering DOH, FC reduction effectiveness, and cost effectiveness. Final conclusions are drawn as follows:

(1) FC reduction effectiveness of HEV is positively related to DOH, which can be expressed by a logarithmic relationship: higher benefits of FC reduction effectiveness can be acquired by improving DOH, when DOH is lower; less benefits of FC reduction effectiveness can be acquired by improving DOH, when DOH is higher.

(2) FC reduction effectiveness of HEV is positively related to cost effectiveness. The cost effectiveness or cost performance is higher for HEV

technologies with better FC reduction effectiveness, and the incremental total cost is also larger.

(3) For different HEV structures, their DOH ranges, FC reduction effectiveness and cost effectiveness vary from each other. BSG structure features rapid achievement of a certain FC reduction with relatively lower total cost, but its cost effectiveness and fuel consumption performance are the poorest; P2 and PS structures have a better performance in both FC reduction effectiveness and cost effectiveness as a whole, with PS more superior than P2; FC reduction effectiveness of SP structure is even better than that of PS structure, but the cost effectiveness is a major constraint. As the SP structure is applied in very few vehicles, further investigation and study is still needed.

References

[1]. Nordelöf A, Messagie M, Tillman A, et al. Environmental impacts of hybrid, plug-in hybrid,

- and battery electric vehicles—what can we learn from life cycle assessment?[J]. *The International Journal of Life Cycle Assessment*, 2014,19(11):1866-1890.
- [2]. Atabani A E, Badruddin I A, Mekhilef S, et al. A review on global fuel economy standards, labels and technologies in the transportation sector[J]. *Renewable and Sustainable Energy Reviews*, 2011,15(9):4586-4610.
- [3]. Rick A, Sisk B. A Simulation Based Analysis of 12V and 48V Microhybrid Systems Across Vehicle Segments and Drive Cycles[J]. *Sae World Congress & Exhibition*, 2015.
- [4]. Kuypers M. Application of 48 Volt for Mild Hybrid Vehicles and High Power Loads[J]. *Sae World Congress & Exhibition*, 2014.
- [5]. Khan I A. *Automotive Electrical Systems: Architecture and Components: Digital Avionics Systems Conference*, 1999[C].
- [6]. Khan I A. *Power Electronics in Automotive Electrical Systems: Power Electronics in Transportation*, 1996[C].
- [7]. Council N R. *Cost, Effectiveness and Deployment of Fuel Economy Technologies for Light-Duty Vehicles*[R].2015.
- [8]. EPA. *Joint Technical Support Document:Final Rulemaking for 2017-2025 Light-Duty Vehicle Greenhouse Gas Emission Standards and Corporate Average Fuel Economy Standards*[J]. 2012.
- [9]. EPA. *Light-Duty Vehicle Technology Cost Analysis, Mild Hybrid and Valvetrain Technology*[R].2011.
- [10]. FEV. *Light-Duty Vehicle Technology Cost Analysis – European Vehicle Market (Phase 1)*[R].2012.
- [11]. EPA. *Light Duty Technology Cost Analysis, Power-Split and P2 HEV Case Studies*[R].2011.
- [12]. Lo, K., A critical review of China's rapidly developing renewable energy and energy efficiency policies. *Renewable and Sustainable Energy Reviews*, 2014. 29: p. 508-516.
- [13]. Nordelöf, A., et al., Environmental impacts of hybrid, plug-in hybrid, and battery electric vehicles—what can we learn from life cycle assessment? *The International Journal of Life Cycle Assessment*, 2014. 19(11): p. 1866-1890.
- [14]. Hannan, M.A., F.A. Azidin and A. Mohamed, Hybrid electric vehicles and their challenges: A review. *Renewable and Sustainable Energy Reviews*, 2014. 29: p. 135-150.
- [15]. Williamson, S.S., *Energy Management Strategies for Electric and Plug-in Hybrid Electric Vehicles*. 2013: Springer New York.
- [16]. Atabani, A.E., et al., A comprehensive review on biodiesel as an alternative energy resource and its characteristics. *Renewable and Sustainable Energy Reviews*, 2012. 16(4): p. 2070-2093.
- [17]. Atabani, A.E., et al., A review on global fuel economy standards, labels and technologies in the transportation sector. *Renewable and Sustainable Energy Reviews*, 2011. 15(9): p. 4586-4610.
- [18]. Modrau, I.S., et al., One-year clinical and angiographic results of hybrid coronary revascularization. *The Journal of Thoracic and Cardiovascular Surgery*.
- [19]. Huang, B. and V. Mauerhofer, Low carbon technology assessment and planning—Case analysis of building sector in Chongming, Shanghai. *Renewable Energy*, 2016. 86: p. 324-331.
- [20]. Gao, G., S. Chen and J. Yang, Carbon emission allocation standards in China: A case study of Shanghai city. *Energy Strategy Reviews*, 2015. 7: p. 55-62.
- [21]. Simmons, R.A., et al., A benefit-cost assessment of new vehicle technologies and fuel economy in the U.S. market. *Applied Energy*, 2015. 157: p. 940-952.
- [22]. Onat, N.C., M. Kucukvar and O. Tatari, Conventional, hybrid, plug-in hybrid or electric vehicles? State-based comparative carbon and energy footprint analysis in the United States. *Applied Energy*, 2015. 150: p. 36-49.
- [23]. Zhang, P., F. Yan and C. Du, A comprehensive analysis of energy management strategies for hybrid electric vehicles based on bibliometrics. *Renewable and Sustainable Energy Reviews*, 2015. 48: p. 88-104.
- [24]. Axsen, J. and K.S. Kurani, Hybrid, plug-in hybrid, or electric—What do car buyers want? *Energy Policy*, 2013. 61: p. 532-543.