

Optimum Design of Hydraulic Excavator

M.Heidari

Mechanical Engineering Group, Abadan Branch, Islamic Azad University, Abadan, Iran.

Abstract

Excavators are heavy construction equipment consisting of a boom, dipper (or stick), bucket and cab on a rotating platform known as the "house". In this paper the hydraulic shovel excavator is analyzed through the D-H method. The shovel working device with the bucket capacity of 36m³ is optimized. The determination of the objective function, variables and constraints are described in detail. The position of optimized shovel is achieved. Also Bucket trajectory and envelope drawing are designed. These are carried on the analysis and comparison. Optimum design is proved rationality.

Keywords: *D-H method, Face-shovel excavator, Genetic algorithm, Optimum design*

Introduction

Excavators (Hydraulic Excavators) are heavy construction equipment consisting of a boom, dipper (or stick), bucket and cab on a rotating platform known as the "house". The house sits atop an undercarriage with tracks or wheels. They are a natural progression from the steam shovels and often mistakenly called power shovels. All movement and functions of a hydraulic excavator are accomplished through the use of hydraulic fluid, with hydraulic cylinders and hydraulic motors. Due to the linear actuation of hydraulic cylinders, their mode of operation is fundamentally different from cable-operated excavators which use winches and steel ropes to accomplish the movements. Modern, hydraulic excavators come in a wide variety of sizes. The smaller ones are called mini or compact excavators. For example, Caterpillar's smallest mini-excavator weighs 2,060 pounds (930 kg) and has 13 hp; their largest model is the largest excavator available (a record previously held by the Orenstein & Koppel RH400), the CAT 6090, which weighs in excess of 2,160,510 pounds (979,990 kg), has 4500 hp and has a bucket size of around 52.0 m³ depending on the bucket fitted. In the design of mechanical products, it is required to determine the size of each member of the mechanism. That is the size design. For the excavator, the working device is the main part of the realization of the mining loading and so on. So the rationality of the excavator size design determines whether the mining mechanism can realize the design function. And at the same time it have good

movement performance and mechanical performance. It has very important significance. According to the design requirements and performance objectives, the size of the mechanism is determined. It need to be analyzed in the body of known size parameters as unknown. From this perspective, the size design more difficult than the mechanism analysis. This property determines the size of the design is a type of mechanical optimization design, can be used to optimize the design of the method and theory to solve. General optimization design contains two levels, that is, the overall design optimization and parameter optimization. Overall scheme optimization is mainly refers to the overall layout structure or system type optimization. In order to obtain the reasonable design, it need to use various disciplines specialized knowledge and rich practical experience. A hydraulic shovel is a construction machinery that can be regarded as a large articulated robot. Digging and loading operations using this machine require a high level of skill, and cause considerable fatigue even in skilled operators. In this paper, the shovel is optimized design according to the existing bucket capacity for a certain type of 36m³ shovel excavator data. Genetic algorithm is used for optimization. It can obtain better results finally.

1. Establishment of the objective function

Excavator is the multivariable and multi-parameter complicated system. It need to meet different design and performance requirements. Multiple optimization objectives is set according

to the different performance need. We know that increasing boom hydraulic cylinder increase the torque. The boom hydraulic cylinder need to provide thrust to overcome the resistance torque in the process of digging or lifting. The resistance torque can be expressed as Eq. (1)

$$M_1 = F_1 e_1 \quad (1)$$

Where F_1 is hydraulic cylinder thrust. If F_1 is a fixed number so the overcome resistance torque is the linear function of movable arm hydraulic cylinder arm e_1 , so the arm is bigger, the resistance torque can overcome more. Therefor according to certain arm swing angle range, in the process of lifting boom arm with the maximum objective function. At the same time, it can guarantee the stability of requires during the process of improvement. Its objective function can be expressed as Eq. (2)

$$\max f_1(x) = \frac{1}{M} \sum_{i=1}^M e_{1i} \quad (2)$$

Where M is the division number of arm hydraulic cylinder arm in the process of ascension.

Optimal design is generally finding minimum value, so the objective function should be written in general form as Eq. (3)

$$\begin{aligned} \min F_1(x) &= -f_1(x) \\ &= -\frac{1}{M} \sum_{i=1}^M e_{1i} \end{aligned} \quad (3)$$

One of the important part is the bucket rod hydraulic cylinder lifting torque. In the limit of limited initial length and elongation of the hydraulic cylinder. In the limit of bucket rod hydraulic cylinder initial length and elongation within the limit, we hope that the maximum thrust of the bucket rod hydraulic cylinder output. Similarly in the boom cylinder optimization target, it can be achieved by increasing the bucket rod hydraulic cylinder arm. The optimization goal can be expressed as Eq. (4)

$$\min F_2(x) = -\frac{1}{N} \sum_{i=1}^N e_{2i} \quad (4)$$

Where N is hydraulic cylinder arm and, e_2 is division number during the excavation process of the bucket rod

Now, the stability of horizontal push shovel is examined. In figure 1, $\theta_1, \theta_2, \theta_3$ are Boom swing angle, Bucket rod swing angle and shovel swing angle respectively in D-H method. γ is the angle between the bucket line BF and the horizontal line. γ_0 is the angle between the

bucket line BF and bucket bottom FV. γ is negative number. γ_0 is positive number. When the bucket bottom surface FV and the bottom surface overlap, there are clearly $\gamma + \gamma_0 = 0$. Leveling Height is h . Due to the origin of coordinates is point O, the horizontal coordinate of the F point is the leveling shovel distance and the vertical coordinate is the height of the leveling shovel. So, h is a negative number. Eq. (5) can be obtained

$$h = OA \cdot \sin\theta_1 + AB \cdot \sin(\theta_1 + \theta_2) + BF \cdot \sin(\theta_1 + \theta_2 + \theta_3) \quad (5)$$

In addition, in the bucket rod quadrilateral ABCD, connecting the BD two points, it can get Eq. (6):

$$BD = \sqrt{AD^2 + AB^2 - 2AD \cdot AB \cdot \cos\angle BAD} \quad (6)$$

Where

$$\angle BAD = \theta_2 + \pi - \angle OAD \quad (7)$$

And Eq. (8) as follows:

$$\begin{aligned} \angle ABC = \angle ABD + \angle CBD &= \arccos \frac{AB^2 + BD^2 - AD^2}{2AB \cdot BD} \\ &+ \arccos \frac{BC^2 + BD^2 - CD^2}{2BC \cdot BD} \end{aligned}$$

Finally Eq. (9) is:

$$\theta_3 = \angle ABC + \angle CBF - \pi \quad (9)$$

The Eq. (9) shows that θ_3 is function of θ_2 and the length of the bucket hydraulic cylinder CD. If the length of bucket hydraulic cylinder CD is known, it can easily solve θ_3 through θ_2 . θ_1 can be solved through θ_3 in Eq.(5). Bucket bottom should be as far as possible close to the ground during horizontal push shovel process. It can meet γ is equal to γ_0 . γ is angle of bucket hinge point connections BF and the horizontal line. γ_0 is angle of the bucket bottom FV. As shown in figure 1. γ_0 Values associated with bucket shape size, generally take $50^\circ \sim 60^\circ$.

According to the above definition, horizontal push shovel can be represented by Eq. (10),

$$\gamma + \gamma_0 = \theta_1 + \theta_2 + \theta_3 + \gamma_0 = 0 \quad (10)$$

It cannot realize the bucket in the strict sense of translation by locking the bucket hydraulic cylinder. By drawing simulation, it is found that if the ABCD connection is able to maintain a parallel. Then θ_1, θ_2 , and θ_3 three angles can be approximated to meet the Eq.(10).

It is required that shovel can try to fit the horizontal movement as far as possible within the traveling range of bucket rod. That is to say, the variation absolute value of angle γ between the bucket and the ground is minimum during horizontal push shovel of process. It can also be

used for the standard deviation of zero. So the objective function of the horizontal push shovel process can be expressed as Eq. (11)

$$\min f_3(x) = \sqrt{\frac{1}{L} \sum_{i=1}^L (\theta_{1i} + \theta_{2i} + \theta_{3i} + \gamma_0)^2} \quad (11)$$

Because of horizontal push shovel bucket hinge connection BF and the horizontal line angle γ requirement is stricter than the bucket translation in the process of ascension. And the function relation between horizontal push shovel movements is more complicated. Horizontal push shovel bucket rod swing angle θ_2 is changed constantly. So horizontal push shovel can be as the main objective function.

3 Genetic algorithm optimization method

3.1 Optimization variables

According to the coordinates of each point in the D-H method. Parameter variables that affect the optimization objective can be determined as shown in figure 2 and the upper and lower bounds of the variables are provided according to the length and the data of the movable arm bucket rod. The corresponding relation of the design parameters and the optimization variables is shown in Table 1.

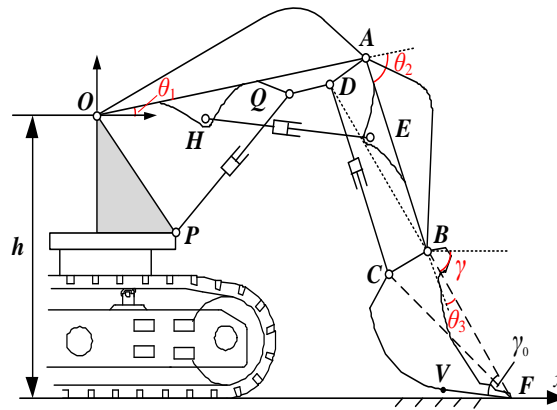

Fig1. Horizontal push shovel model diagram

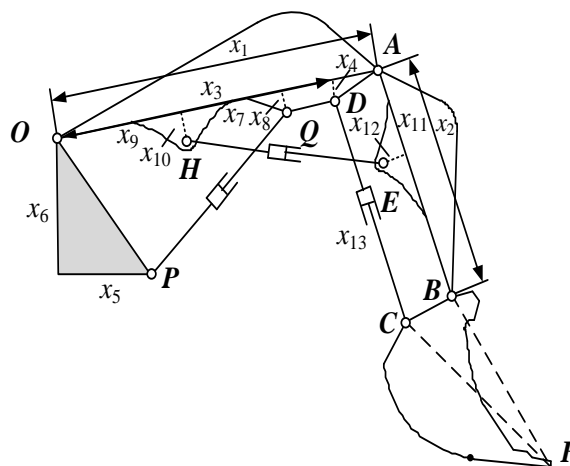

Fig2. Schematic diagram of optimization variables

Table 1. The corresponding relationship between the design parameters and the optimization variables

parameter name	Optimization variables	scope of upper and lower limits (mm)
<i>OA</i>	x_1	7900 ~ 8300
<i>AB</i>	x_2	4700 ~ 5500
${}^{01}D_x$	x_3	6500 ~ 7300
${}^{01}D_y$	x_4	-200 ~ 200
P_x	x_5	1300 ~ 1650
P_y	x_6	-2600 ~ -2300
${}^{01}Q_x$	x_7	5400 ~ 6000
${}^{01}Q_y$	x_8	-200 ~ 200
${}^{01}H_x$	x_9	2200 ~ 3500
${}^{01}H_y$	x_{10}	-550 ~ -350
${}^A E_x$	x_{11}	1300 ~ 1800
${}^A E_y$	x_{12}	-600 ~ -350
<i>CD</i>	x_{13}	4500~5500

3.2. The optimization design of constraints

According to the geometrical condition, transmission angle, the motion performance and movement range of shovel excavator working device, the following several optimization constraints are set up.

3.2.1 The maximum radius of mining

The maximum radius of mining constraint can be expressed as Eq. (12)

$$x_0 + OA \cdot \cos\theta_1 + AB \cdot \cos(\theta_1 + \theta_{2max}) + BF - R_{max} \geq 0 \tag{12}$$

3.2.2 The largest mining height

The largest mining height constraint can be expressed as Eq. (13)

$$OA \cdot s\theta_{1max} + AB \cdot s(\theta_{1max} + \theta_{2max}) + BF \cdot s(\theta_{1max} + \theta_{2max} + \theta_{3max}) - H_{max} \geq 0 \tag{13}$$

3.2.3 The maximum horizontal push shovel of distance

The distance of the maximum horizontal push shovel constraint expression can be used as Eq. (14):

$$x_0 + OA \cdot c\theta_1 + AB \cdot c(\theta_1 + \theta_{2max}) + BF \cdot c(\theta_1 + \theta_{2max} + \theta_3) - L_{max} \geq 0 \tag{14}$$

3.2.4 Hydraulic cylinder transmission angle

Hydraulic cylinder transmission angle can be expressed as Eq. (15):

$$\alpha = \arccos \frac{Q_x(Q_x - P_x) + Q_y(Q_y - P_y)}{\sqrt{Q_x^2 + Q_y^2} \sqrt{(Q_x - P_x)^2 + (Q_y - P_y)^2}} \geq \alpha_0 \tag{15}$$

3.2.5 Swing angle constraint

Swing angle constraint can be expressed as Eq. (16):

$$\frac{OP^2 + OQ^2 - l_1^2}{2OP \cdot OQ} \leq \cos(\theta_{1min} - \angle AOQ + \angle POx) \tag{16}$$

$$\frac{OP^2 + OQ^2 - (1.65l_1)^2}{2OP \cdot OQ} \geq \cos(\theta_{1max} - \angle AOQ + \angle POx)$$

3.3 Optimization using Matlab genetic algorithm toolbox

Hydraulic face-shovel excavator is optimal designed using Matlab genetic algorithm toolbox. Three objective function of the horizontal push shovel, hydraulic cylinder moving arm and hydraulic cylinder bucket rod arm is respectively programmed by MATLAB. They were saved as "section1.m" "section2.m" "section3.m" function file and the corresponding optimization variables are used as the input of the corresponding function. Open optimization toolbox to optimize. The simulation interface of the target function of the horizontal push shovel is shown in Fig. 3.

The MATLAB genetic algorithm toolbox is used to obtain the optimal data of horizontal push shovel and the population fitness. It is shown in figure 4 and figure 5 respectively.

The optimized coordinates and length data were shown in Table 2.

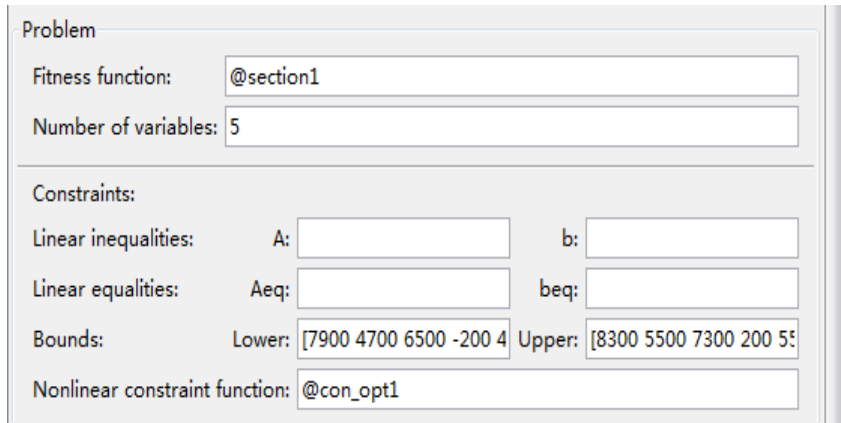

Fig3. The simulation interface of the target function of the horizontal push shovel

Final point:				
1	2	3	4	5
7,982.414	4,831.198	7,136.221	0.482	5,051.411

Fig4. Horizontal push shovel optimization data

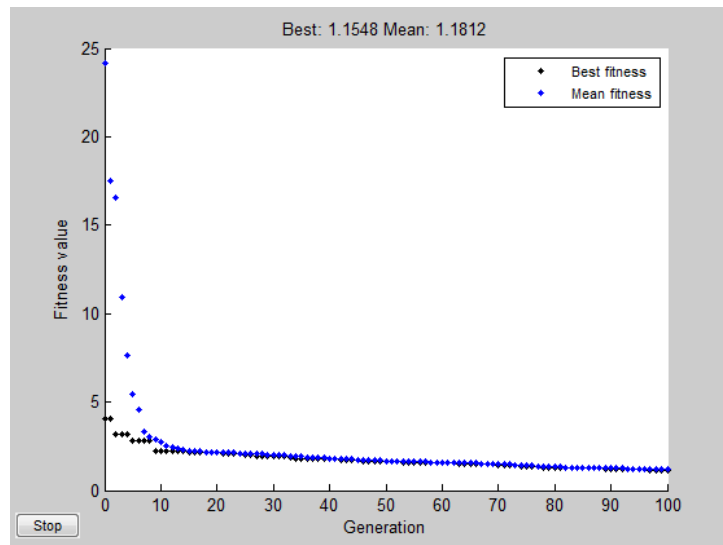

Fig5. Optimization of population fitness change with horizontal push shovel

3.4 Contrast before and after optimization

The parameters of before and after optimization were input in MATLAB horizontal push shovel function. Comparison results can be got as shown in Fig. 6. The image shows that before optimization horizontal push shovel distance is 4595 mm. The angle ϵ of bucket bottom and the bottom in the process of horizontal push shovel changes from -0.838° to 12.84° .

Variation is $\Delta\epsilon = 13.67^\circ$. The optimized horizontal push shovel distance is 5581 mm. The angle ϵ of bucket bottom and the bottom in the process of horizontal push shovel changes from 3.757° to -0.461° . Variation is $\Delta\epsilon = 4.218^\circ$.

It can get result that excavator horizontal push shovel performance with the optimized parameters is far superior to of the before optimization.

Table 2. Optimization results of design parameters

Parameter name	Optimization variables	optimization result (mm)
OA	x_1	7980
AB	x_2	4830
${}^{01}D_x$	x_3	7136
${}^{01}D_y$	x_4	0
P_x	x_5	1592
P_y	x_6	-2600
${}^{01}Q_x$	x_7	5995
${}^{01}Q_y$	x_8	-7
${}^{01}H_x$	x_9	2823
${}^{01}H_y$	x_{10}	-500
${}^A E_x$	x_{11}	1800
${}^A E_y$	x_{12}	-565
CD	x_{13}	5050

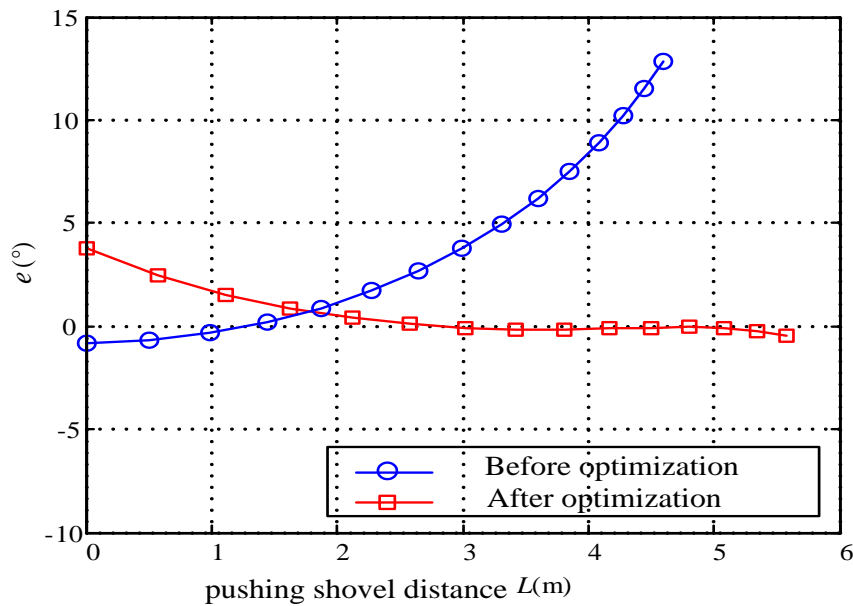

Fig6. Before and after optimization in the process of horizontal push shovel

4. Conclusion

Based on the typical mining and lifting process using genetic algorithm to optimize the parameters of the working device. After optimization the boom, bucket rod and bucket mechanism transmission angle increased. The stroke of hydraulic cylinders is shorten. Arm hydraulic cylinder lifting force more in line with the full bucket by any mining location to ascend to the unloading

point place needs power changes, the bucket rod hydraulic cylinder of the digging force and bucket hydraulic cylinder of the digging force optimization than before more in line with the digging resistance of materials changes.

REFERENCES

1. Yokota, Shinichi; Sasao, Masanori, Ichiryu, Ken. Trajectory control of the boom and arm system of hydraulic excavators. Transactions of the Japan Society of Mechanical Engineers, Part C. vol. 62, no. 593, pp. 161-167, 1996.
2. Pyung Hun Chang; Lee, S.-J. A straight-line motion tracking control of hydraulic excavator system. Mechatronics, vol. 12, no. 1, pp. 119-138, 2002.
3. Rudolph. Convergence Analysis of Canonical Genetic Algorithms. IEEE Trans on Neural Networks. vol. 5, no. 1, pp. 96-101, 1994.
4. Mottl, J. Excavator optimization using the "voting method". Computer Methods in Applied Mechanics and Engineering. vol. 98, no. 2, pp. 227-250, 1992.
5. Ward Peter, Wakeling Andrew; Weeks Richard, etc. Design Of An Excavator Arm Using Optimization Techniques. SAE Technical Paper Series. vol. 6, no. 5, pp. 64-67, 1987.
6. Ka Iyanmoy Deb. Design for a Weld Beam via Genetic Algorithms. AIAA Journal. vol. 29, no. 11, pp. 444-445, 1991.